

RECOMMENDATION ITU-R SM.328-10

SPECTRA AND BANDWIDTH OF EMISSIONS

(Question ITU-R 76/1)

(1948-1951-1953-1956-1959-1963-1966-1970-1974-1978-1982-1986-1990-1994-1999)

The ITU Radiocommunication Assembly,

considering

- a) that in the interest of an efficient use of the radio spectrum, it is essential to establish for each class of emission rules governing the spectrum emitted by a transmitting station;
- b) that, for the determination of an emitted spectrum of optimum width, the whole transmission circuit as well as all its technical working conditions, including other circuits and radio services sharing the band, the transmitter frequency tolerances of Recommendation ITU-R SM.1045, and particularly propagation phenomena, should be taken into account;
- c) that the concepts of “necessary bandwidth” and “occupied bandwidth” defined in Nos. S1.152 and S1.153 of the Radio Regulations (RR), are the basis for specifying the spectral properties of a given emission, or class of emission, in the simplest possible manner;
- d) that, however, these definitions do not suffice when consideration of the complete problem of radio spectrum economy and efficiency is involved; and that an endeavour should be made to establish rules limiting, on the one hand, the bandwidth occupied by an emission to the most efficient value in each case and, on the other hand, the amplitudes of the components emitted in the outer parts of the spectrum so as to decrease interference to adjacent channels;
- e) that with regard to the efficient use of the radio-frequency spectrum necessary bandwidths for individual classes of emission must be known, that in some cases the formulae listed in Recommendation ITU-R SM.1138, can only be used as a guide and that the necessary bandwidth for certain classes of emissions is to be evaluated corresponding to a specified transmission standard and a quality requirement;
- f) that the occupied bandwidth enables operating agencies, national and international organizations, to carry out measurements to quantify the bandwidth actually occupied by a given emission and thus to ascertain, by comparison with the necessary bandwidth, that such an emission does not occupy an excessive bandwidth for the service to be provided and is, therefore, not likely to create interference beyond the limits laid down for this class of emission;
- g) that, in addition to limiting the spectrum occupied by an emission to the most efficient value in each case, rules have been established in Recommendation ITU-R SM.329 to limit the amplitudes of the spurious emission components;
- h) that there is a need to define the necessary bandwidth of a transmission to perform measurement of spurious emissions in accordance with Recommendation ITU-R SM.329;
- j) that methods of measurement for intermodulation distortion products have been established in Recommendation ITU-R SM.326 and that limits are to be found in Recommendation ITU-R SM.329;
- k) that in several cases, the use of systems employing necessary bandwidths much greater than the baseband bandwidth (e.g. systems which employ high modulation index FM or other bandwidth expansion techniques) potentially increase the number of users sharing a band, because the susceptibility of receivers to interference may be reduced sufficiently to more than compensate for the reduction in the number of channels available, thus increasing the efficiency of radio spectrum use,

recommends

1 Definitions

that the following definitions should be used when dealing with bandwidth, channel spacing and interference problems:

1.1 Baseband

The band of frequencies occupied by one signal, or a number of multiplexed signals, which is intended to be conveyed by a line or a radio transmission system.

NOTE 1 – In the case of radiocommunication, the baseband signal constitutes the signal modulating the transmitter.

1.2 Baseband bandwidth

The width of the band of frequencies occupied by one signal, or a number of multiplexed signals, which is intended to be conveyed by a line or a radio transmission system.

1.3 Necessary bandwidth

For a given class of emission, the width of the frequency band which is just sufficient to ensure the transmission of information at the rate and with the quality required under specified conditions (RR No. S1.152).

1.4 Bandwidth expansion ratio

The ratio of the necessary bandwidth to baseband bandwidth.

1.5 Out-of-band spectrum (of an emission)

The part of the power density spectrum (or the power spectrum when the spectrum consists of discrete components) of an emission which is outside the necessary bandwidth and which results from the modulation process, with the exception of spurious emissions.

1.6 Out-of-band emission

Emission on a frequency or frequencies immediately outside the necessary bandwidth which results from the modulation process, but excluding spurious emissions (RR No. S1.144).

NOTE 1 – Non-linearity in amplitude modulated transmitters (including single-sideband transmitters) may result in out-of-band emissions which are immediately adjacent to the necessary bandwidth, due to odd order intermodulation products.

1.7 Spurious emission

Emission on a frequency or frequencies which are outside the necessary bandwidth and the level of which may be reduced without affecting the corresponding transmission of information. Spurious emissions include harmonic emissions, parasitic emissions, intermodulation products and frequency conversion products, but exclude out-of-band emissions (see RR No. S1.145). The maximum permissible level of spurious emissions is specified in Recommendation ITU-R SM.329 for all radio services.

1.8 Unwanted emissions

Consist of spurious emissions and out-of-band emissions (see RR No. S1.146).

1.9 Emission terminology

The terms associated with the definitions given in § 1.6, 1.7 and 1.8 above are expressed in the working languages as shown in Table 1.

TABLE 1

English	French	Spanish
Out-of-band emission	Emission hors bande	Emisión fuera de banda
Spurious emission	Rayonnement non essentiel	Emisión no esencial
Unwanted emissions	Rayonnements non désirés	Emisiones no deseadas

1.10 Permissible out-of-band spectrum (of an emission)

For a given class of emission, the permissible level of the power density (or the power of discrete components) at frequencies above and below the limits of the necessary bandwidth.

NOTE 1 – The permissible power density (or power) may be specified in the form of a limiting curve giving the power density (or power), expressed in decibels relative to the specified reference level, for frequencies outside the necessary bandwidth. The abscissa of the initial point of the limiting curve should coincide with the limiting frequencies of the necessary bandwidth. Descriptions of limiting curves for various classes of emissions are given in Annexes 1 to 6.

1.11 Out-of-band power (of an emission)

The total power emitted at the frequencies of the out-of-band spectrum.

1.12 Permissible out-of-band power

For a given class of emission, the permissible level of mean power emitted at frequencies above and below the limits of necessary bandwidth.

NOTE 1 – The permissible level of out-of-band power should be determined for each class of emission and specified as a percentage β of total mean power radiated derived from the limiting curve fixed individually for each class of emission.

1.13 Occupied bandwidth

The width of a frequency band such that, below the lower and above the upper frequency limits, the mean powers emitted are each equal to a specified percentage $\beta/2$ of the total mean power of a given emission.

Unless otherwise specified by the Radiocommunication Assembly for the appropriate class of emission, the value of $\beta/2$ should be taken as 0.5% (see RR No. S1.153).

1.14 x dB bandwidth

The width of a frequency band such that beyond its lower and upper limits any discrete spectrum component or continuous spectral power density is at least x dB lower than a predetermined 0 dB reference level.

1.15 Assigned frequency band

The frequency band within which the emission of a station is authorized; the width of the band equals the necessary bandwidth plus twice the absolute value of the frequency tolerance. Where space stations are concerned, the assigned frequency band includes twice the maximum Doppler shift that may occur in relation to any point of the Earth's surface (see RR No. S1.147).

1.16 Assigned frequency

The centre of the frequency band assigned to a station (see RR No. S1.148).

1.17 Characteristic frequency

A frequency which can be easily identified and measured in a given emission.

A carrier frequency may, for example, be designated as the characteristic frequency (see RR No. S1.149).

1.18 Reference frequency

A frequency having a fixed and specified position with respect to the assigned frequency. The displacement of this frequency with respect to the assigned frequency has the same absolute value and sign that the displacement of the characteristic frequency has with respect to the centre of the frequency band occupied by the emission (see RR No. S1.150).

1.19 Frequency tolerance

The maximum permissible departure by the centre frequency of the frequency band occupied by an emission from the assigned frequency or, by the characteristic frequency of an emission from the reference frequency.

The frequency tolerance is expressed in parts in 10^6 or in hertz (see RR No. S1.151).

1.20 Build-up time of a telegraph signal

The time during which the telegraph current passes from one-tenth to nine-tenths (or *vice versa*) of the value reached in the steady state; for asymmetric signals, the build-up times at the beginning and end of a signal can be different.

1.21 Relative build-up time of a telegraph signal

Ratio of the build-up time of a telegraph signal defined in § 1.20 to the half-amplitude pulse duration.

1.22 Modulation rate

The modulation rate (Bd), B , used in the following text is the maximum speed used by the corresponding transmitter. For a transmitter operating at a speed lower than this maximum speed, the build-up time should be increased to keep the occupied bandwidth at a minimum, to comply with RR No. S3.9.

2 Emission of a transmitter, optimum from the standpoint of spectrum efficiency

that an emission should be considered optimum from the standpoint of spectrum efficiency when its occupied bandwidth coincides with the necessary bandwidth for the class of emission concerned.

An optimum bandwidth from the standpoint of spectrum efficiency may not be optimum from the standpoint of spectrum usage in a sharing situation.

2.1 The following are examples of spectra illustrating the definitions of out-of-band power, necessary bandwidth and x dB bandwidth.

FIGURE 1
Evaluation of spectra, by comparing out-of-band power and band limitation

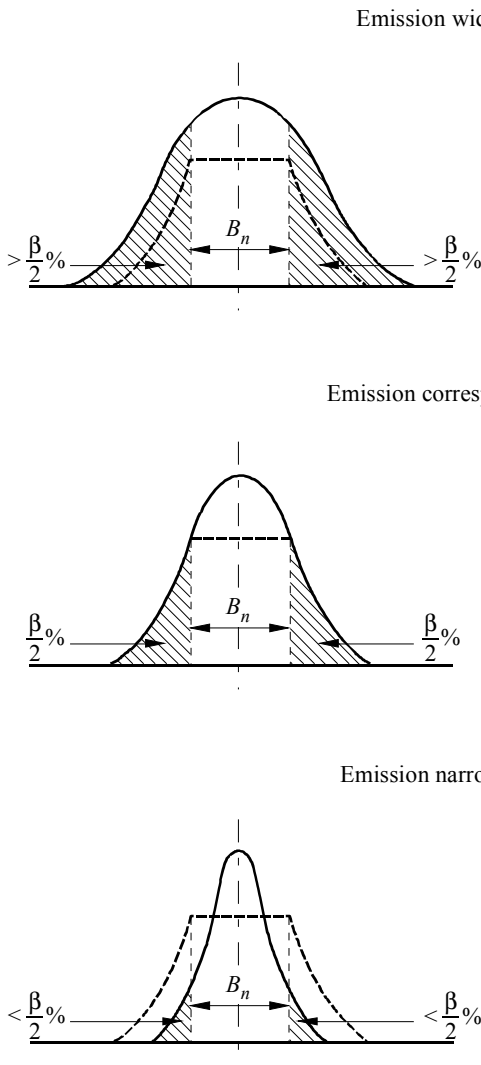
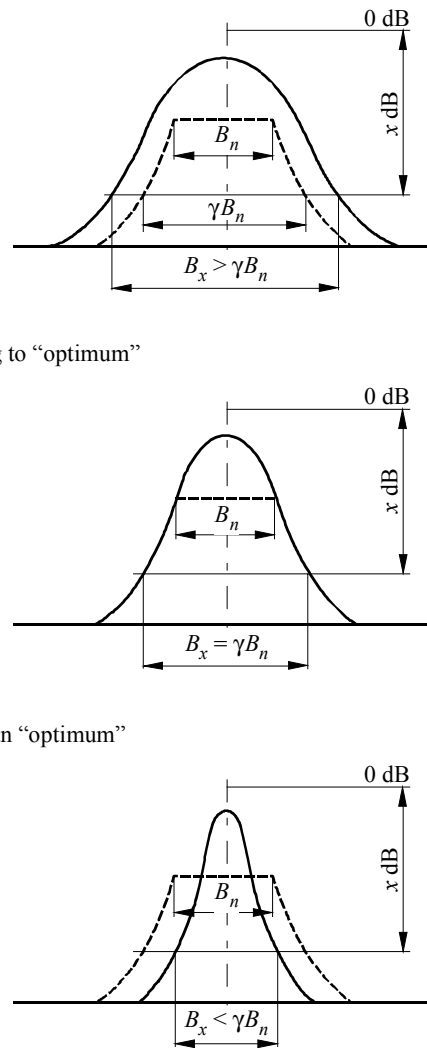

FIGURE 2
Evaluation of spectra by means of the x dB bandwidth



- B_n : necessary bandwidth
- B_x : x dB bandwidth
- x : value of measurement level (dB)
- γ : required relationship between x dB bandwidth and necessary bandwidth, determined by the x dB level and the parameters of the limiting curve for the out-of-band spectrum
- $\frac{\beta}{2}$: half of the permissible out-of-band power

3 Limits for out-of-band emissions

that this Recommendation could be used as guidance in deriving the limits for out-of-band emissions. Such limits should be defined considering the degradation caused by modulation imperfections, phase noise, intermodulation and practical limitations on filter implementation.

4 Calculation of emitted spectra

that values for emission components can be calculated for the emission types identified in RR Appendix S1. Annexes 1 to 6 should be used to calculate the following emissions types which contain the analytical models and other considerations which may be utilized as the basis determining the values in measurement of occupied bandwidth:

- emissions designated Type A (see Annex 1);
- emissions designated Types B and R (see Annex 2);
- emissions designated Type F (see Annex 3);
- emissions designated Type G (see Annex 4);
- emissions designated Type J (see Annex 5);
- digital phase modulation (see Annex 6).

4.1 Approximation of out-of-band spectra envelopes for analytical calculations

For an approximation of out-of-band spectra envelopes by power functions the following formula should be used:

$$S_1(f) = S(f_m) \left(\frac{f_m}{f} \right)^\gamma \quad (1)$$

$$\gamma = 0.33 N$$

where $S(f_m)$ is the power on a given frequency f_m , and N is a number of dB by which the spectrum envelope is reduced within a single octave of band widening.

For another approximation of out-of-band spectra envelopes by exponential functions the following formula should be used:

$$S_2(f) = S(f_m) \exp \left[-\frac{0.23 N_1}{f_m} (f - f_m) \right] \quad (2)$$

where N_1 represents the number of dB corresponding to the first octave of band widening. For the most common values of $N = 12$ to 20 dB/octave, it is sufficient to carry out the power comparison at a very low accuracy of about $\pm 15\%$ to 20% to ensure an occupied bandwidth measurement accuracy of $\pm 3\%$ to $7\%^*$.

These methods consist in comparing the total power of the emission with the power remaining after filtering, either by means of two low-pass filters or two high-pass filters, or by a high-pass filter, or by a high-pass and a low-pass filter, the cut-off frequencies of which can be shifted at will with respect to the spectrum of the emission. Alternatively, the relevant power constituents can be determined by evaluating the power spectrum as obtained by a spectrum analyser.

* *Note by the Secretariat:* The relationship between the percentage error in measuring the occupied bandwidth and the percentage error in the power comparison, for different values of N is shown in Fig. 71 of the ITU-R Spectrum Monitoring Handbook (Geneva, 1995).

5 Reduction of interference due to unwanted emissions at transmitters

that the following methods are some of those that should be used to reduce the unwanted emissions of a transmitter (details of these methods are described in Annex 7):

- transmitter architecture (see Annex 7, § 1);
- filtering (see Annex 7, § 2);
- modulation techniques (see Annex 7, § 3);
- linearization (see Annex 7, § 4);
 - predistortion (see Annex 7, § 4.1);
 - feedforward (see Annex 7, § 4.2);
 - feedback (see Annex 7, § 4.3);
 - modulation feedback (see Annex 7, § 4.4);
 - the Polar Loop technique (see Annex 7, § 4.5);
 - the Cartesian Loop technique (see Annex 7, § 4.6).

NOTE – In view of the wide variety of different architectures and possible methods of reducing emissions, the above list should not be understood as comprehensive.

Annexes to the present Recommendation

ANNEX 1 – Considerations for emissions designated Type A (double sideband)

ANNEX 2 – Considerations for emissions designated Types B and R (independent sideband and single sideband)

ANNEX 3 – Considerations for emissions designated Type F (frequency modulation)

ANNEX 4 – Considerations for emissions designated Type G (phase modulation)

ANNEX 5 – Considerations for emissions designated Type J (single sideband, suppressed carrier)

ANNEX 6 – Digital phase modulation

ANNEX 7 – Reduction of interference due to unwanted emissions at transmitters

Considerations for emissions designated Type A

(Double sideband)

TABLE OF CONTENTS

	<i>Page</i>	
1	Classes of emission A1A and A1B with fluctuations	8
	1.1 Necessary bandwidth	9
	1.2 Shape of the spectrum envelope.....	9
	1.3 Occupied bandwidth.....	9
	1.4 Out-of-band spectrum	9
	1.5 Build-up time of the signal.....	9
	1.6 Adjacent-channel interference.....	9
2	Classes of emission A1A and A1B without fluctuations	10
3	Shaping of the telegraph signal by means of filters.....	10
4	Classes of emission A2A and A2B.....	10
	4.1 Necessary bandwidth	10
	4.2 Out-of-band spectrum	10
5	Amplitude-modulated radiotelephone emission, excluding emissions for sound broadcasting.....	11
	5.1 Type of modulation signal and adjustment of the input signal level.....	11
	5.2 Extract from ITU-T Recommendation G.227	12
	5.3 Class of emission A3E double-sideband telephony	13
	5.3.1 Necessary bandwidth.....	13
	5.3.2 Power within the necessary band.....	13
	5.3.3 Out-of-band spectrum.....	14
	5.3.4 Relationships between the 0 dB reference level for determining the out-of-band spectrum and the levels of other spectral components of the emission	15
	5.4 Single-sideband, classes of emission R3E, H3E and J3E (reduced, full or suppressed carrier) and independent-sideband class of emission B8E.....	15
	5.4.1 Necessary bandwidth.....	15
	5.4.2 Power within the necessary band.....	16
	5.4.3 Out-of-band spectrum for class of emission B8E; four telephony channels simultaneously active	16
6	Amplitude-modulated emissions for sound broadcasting.....	17
	6.1 Type of modulation signal and adjustment of the input signal level, class of emission A3EGN, sound broadcasting.....	17
	6.2 Noise signal for modulating the signal generators (Extract from Recommendation ITU-R BS.559, § 1.3).....	17
	6.3 Class of emission A3E, double-sideband sound broadcasting	18
	6.3.1 Necessary bandwidth.....	19
	6.3.2 Power within the necessary band.....	19
	6.3.3 Out-of-band spectrum.....	19
	6.3.4 Relationship between the 0 dB reference level for determining the out-of-band spectrum and the levels of other spectral components of the emission	19

1 Classes of emission A1A and A1B with fluctuations

When large short-period variations of the received field are present, the specifications given below for single-channel, amplitude-modulated, continuous-wave telegraphy (Class A1A and A1B), represent the desirable performance obtainable from a transmitter with an adequate input filter and sufficiently linear amplifiers following the stage in which keying occurs.

1.1 Necessary bandwidth

The necessary bandwidth is equal to five times the modulation rate (Bd). Components at the edges of the band are at least 3 dB below the levels of the same components of a spectrum representing a series of equal rectangular dots and spaces at the same modulation rate.

This relative level of -3 dB corresponds to an absolute level of 27 dB below the mean power of the continuous emission (see Recommendation ITU-R SM.326, Table 1).

1.2 Shape of the spectrum envelope

The amplitude of the spectrum envelope relative to the amplitude of the continuous emission is shown in Fig. 3 as a function of the order of the sideband components, assuming that the envelope of the RF signal is a square wave. In this figure, the order n , of the sideband component is given by:

$$n = \frac{2f}{B} \quad (3)$$

where:

f : frequency separation from the centre of the spectrum (Hz)

B : modulation rate (Bd).

1.3 Occupied bandwidth

The occupied bandwidth, L (Hz) for an out-of-band power ratio $\beta = 0.01$ may be calculated from the following empirical formula:

$$L = \left(\frac{1}{0.05 + \alpha} - 1 \right) B \quad (4)$$

where:

α : relative build-up time of the shortest pulse of a telegraph signal as defined in § 1.21

B : modulation rate (Bd).

The maximum divergence between the results obtained by using this formula and the results of accurate calculations is $2B$ when $\alpha < 0.02$; and B when $\alpha \geq 0.02$. This has also been confirmed by measurements. Equation (3) may therefore be used for the indirect measurement of occupied bandwidth of A1A and A1B emissions.

1.4 Out-of-band spectrum

If frequency is plotted as the abscissa in logarithmic units and if the power densities are plotted as ordinates (dB) the curve representing the out-of-band spectrum should lie below two straight lines starting at point $(+5B/2, -27 \text{ dB})$ or at point $(-5B/2, -27 \text{ dB})$ defined above, with a slope of 30 dB/octave and finishing at point $(+5B, -57 \text{ dB})$ or $(-5B, -57 \text{ dB})$, respectively. Thereafter, the same curve should lie below the level -57 dB .

The permissible amounts of out-of-band power, above and below the frequency limits of the necessary bandwidth, are each approximately 0.5% of the total mean power radiated.

1.5 Build-up time of the signal

The build-up time of the emitted signal depends essentially on the shape of the signal at the input to the transmitter, on the characteristics of the filter to which the signal is applied, and on any linear or non-linear effects which may take place in the transmitter itself (assuming that the antenna has no influence on the shape of the signal). As a first approximation, it may be assumed that an out-of-band spectrum close to the limiting curve defined in § 1.4 corresponds to a build-up time of about 20% of the initial duration of the telegraph dot, i.e. about $1/5 B$.

1.6 Adjacent-channel interference

Interference to adjacent channels depends on a large number of parameters and its rigorous calculation is difficult. Since it is not necessary to calculate the values of interference with great precision, semi-empirical equations and graphs can be used.

2 Classes of emission A1A and A1B without fluctuations

For amplitude-modulated, continuous-wave telegraphy, when short-period variations of the received field strength do not affect transmission quality, the necessary bandwidth can be reduced to three times the modulation rate (Bd).

3 Shaping of the telegraph signal by means of filters

Increasing the build-up time of the telegraph signal to the maximum value compatible with the proper operation of the receiving equipment is a suitable means of reducing occupied bandwidth.

The minimum value of the ratio, T , of the 6 dB passband of such filters to half the modulation rate (Bd), is largely dependent on the synchronization requirements of the receiver terminal equipment, the frequency stability of both the transmitter and receiver and, in the case of actual traffic, also on the propagation conditions. The minimum value may vary from 2, when synchronization and stability are extremely good, to 15 when the frequency drift is appreciable and teletype equipment is used.

Minimum overshoot filters preferably should be used in order to fully utilize the transmitter power.

Table 2 shows, as a function of T , the percentage or time during which the signal element is not within 1% for a minimum overshoot filter.

TABLE 2

$\frac{\text{Length of flat portion}}{\text{Length of signal element}}$	0% (sinusoidal signal)	50%	90%	100% (rectangular signal)
T	1.6	3.2	16	∞

Since the ratio T is predetermined, it may be necessary to use a filter consisting of several sections to sufficiently reduce the components in the outer parts of the spectrum.

4 Classes of emission A2A and A2B

For single-channel telegraphy, in which both the carrier frequency and the modulating oscillations are keyed, the percentage of modulation not exceeding 100% and the modulation frequency being higher than the modulation rate ($f > B$), the requirements given below represent the desirable performance that can be obtained from a transmitter with a fairly simple input filter and approximately linear stages.

4.1 Necessary bandwidth

The necessary bandwidth is equal to twice the modulating frequency f plus five times the modulation rate (Bd).

4.2 Out-of-band spectrum

If the frequency is plotted as the abscissa in logarithmic units and the power densities are plotted as ordinates (dB) the curve representing the out-of-band spectrum should lie below two straight lines starting at point $(+(f + 5 B/2), -24 \text{ dB})$, or at point $(-(f + 5 B/2), -24 \text{ dB})$, with a slope of 12 dB/octave, and finishing at point $(+(f + 5 B), -36 \text{ dB})$ or $(-(f + 5 B), -36 \text{ dB})$, respectively. Thereafter, the same curve should be below the level -36 dB .

The reference level, 0 dB, corresponds to that of the carrier in a continuous emission with modulating oscillation.

The permissible amounts of out-of-band power above and below the frequency limits of the necessary bandwidth are each approximately 0.5% of the total mean power radiated.

5 Amplitude-modulated radiotelephone emission, excluding emissions for sound broadcasting

The occupied bandwidth and out-of-band radiation of amplitude-modulated emissions carrying analogue signals depend, to a varying degree, on several factors such as:

- type of modulating signal;
- the input signal level determines the modulation loading of the transmitter;
- the passband which results from the filters used in the audio-frequency stages and in the intermediate and final modulating stages of the transmitter;
- the magnitude of the harmonic distortion and intermodulation components at the frequencies of the out-of-band spectrum.

The spectrum limits described in this section for radiotelephone emissions have been deduced from various measurements. The peak envelope power of the transmitter is first determined using the method described in Recommendation ITU-R SM.326, § 3.1.3, and the transmitter is adjusted for an acceptable distortion for the class of service.

Measurements have been made using several different modulating signals substituted for the two audio tones. It has been found that white or weighted noise, with the bandwidth limited by filtering to the desired bandwidth of the information to be transmitted in normal service, is a satisfactory substitute for a speech signal in making practical measurements.

In the out-of-band emission curves defined in § 5.3 and 5.4, the ordinates represent the energy intercepted by a receiver of 3 kHz bandwidth, the central frequency of which is tuned to the frequency plotted on the abscissa, normalized to the energy which is intercepted by the same receiver when tuned to the central frequency of the occupied band.

However, a receiver with 3 kHz bandwidth cannot provide detailed information in the frequency region close to the edge of the occupied band. It has been found that point-by-point measurements with a receiver having an effective bandwidth of 100 to 250 Hz or with a spectrum analyser with a similar filter bandwidth are more useful in analysing the fine structure of the spectrum.

To make these measurements, the attenuation-frequency characteristics of the filter limiting the transmitted bandwidth should first be determined. The transmitter is then supplied with a source of white noise or weighted noise, limited to a bandwidth somewhat larger than the filter bandwidth.

In applying the input signal to transmitter, care should be taken that, at the output, the peaks of the signal do not exceed the peak envelope power of the transmitter or the level corresponding to a modulation factor of 100%, whichever is applicable, for more than a specific small percentage of time. This percentage will depend on the class of emission.

5.1 Type of modulation signal and adjustment of the input signal level

As the statistical distribution of the noise amplitude is almost independent of bandwidth and is not significantly altered when a linear weighting network is used, the following procedure is suitable for simulating the loading of a transmitter under actual traffic conditions.

The transmitter is first modulated with a sinusoidal signal to a modulation factor of 100%. Next, the sinusoidal signal is replaced by a noise signal, the level of which is adjusted until the r.m.s. voltage after linear demodulation of the radio-frequency signal is equal to 35% of the r.m.s. voltage which was produced by the sinusoidal signal.

With this adjustment, which applies equally to a modulating signal consisting of white noise or of weighted noise, the envelope of the noise-modulated signal will not exceed the level corresponding to a modulation factor of 100% for more than about 0.01% of the time, according to the curve shown in Fig. 3.

The levels should preferably be measured at the output of the transmitter, as explained above, in order to avoid errors due to different values of the noise bandwidth, which may occur when the noise level is determined at the input or at the output of the band-limiting filters used in the transmitter.

FIGURE 3

Time Φ (%) during which the instantaneous value of the white noise exceeds the threshold voltage $\pm u$, as a function of the ratio x

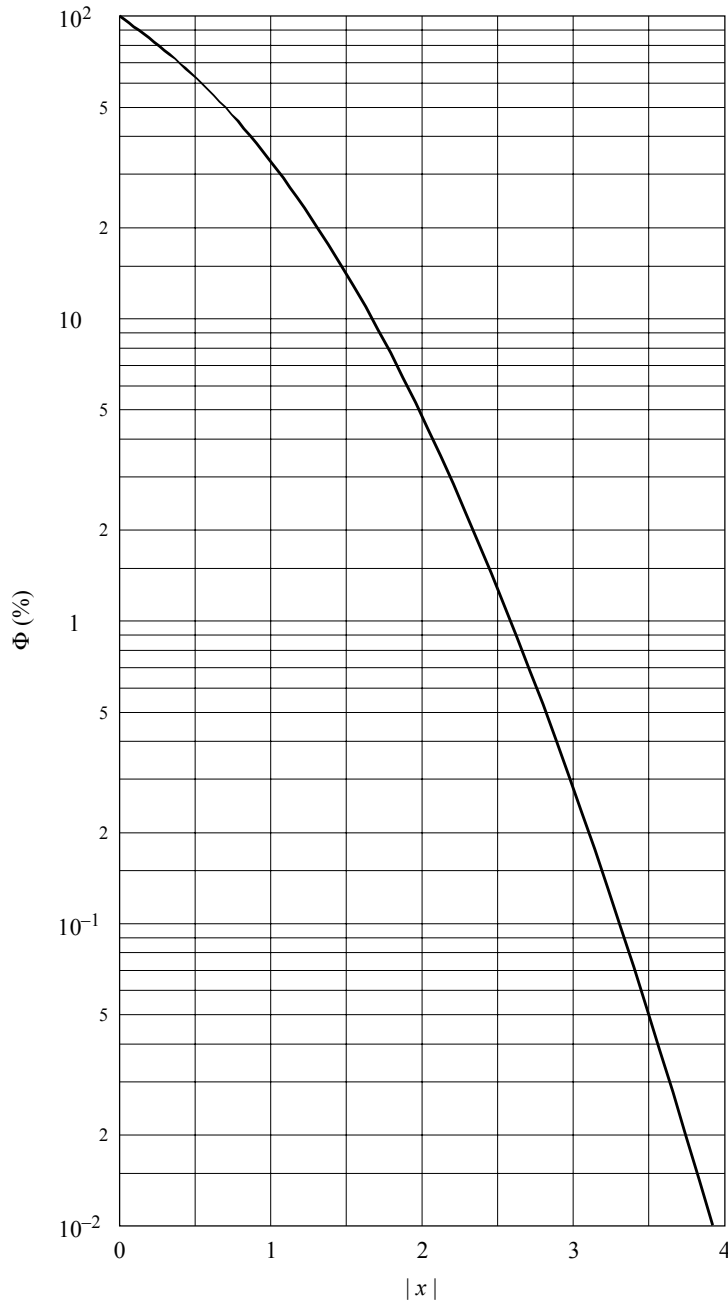

x is given by $|x| = |u| / U_{rms}$
where:

U_{rms} : r.m.s. noise voltage
 u : threshold level

0328-03

5.2 Extract from ITU-T Recommendation G.227

The relative response curve and the electrical diagram of the shaping network of the conventional telephone signal generator are given in Figs. 4 and 5, accordingly.

FIGURE 4
**Relative response curve of the shaping network
of the conventional telephone signal generator**

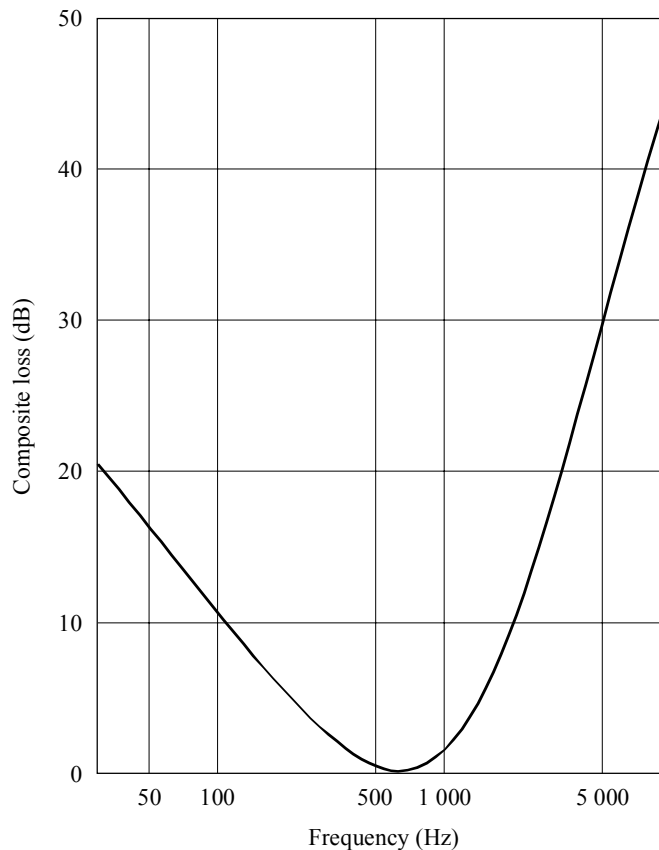

0328-04

5.3 Class of emission A3E double-sideband telephony

5.3.1 Necessary bandwidth

The necessary bandwidth, F , is, in practice, equal to twice the highest modulation frequency, M , which it is desired to transmit with a specified small attenuation.

5.3.2 Power within the necessary band

The statistical distribution of power within the necessary band is determined by the relative power level of the different speech frequency components applied at the input to the transmitter or, when more than one telephony channel is used, by the number of active channels and the relative power level of the speech frequency components, applied at the input to each channel.

When no privacy equipment is connected to the transmitter, the power distribution of the different speech frequency components in each channel may be assumed to correspond to the curve given in Fig. 4. This curve is not applicable to sound broadcasting.

If the transmitter is used in connection with a frequency inversion privacy equipment, the same data can be used with appropriate frequency inversion of the resulting spectrum.

If a band-splitting privacy equipment is used, it may be assumed that the statistical distribution of power is uniform within the frequency band.

FIGURE 5

Shaping network of the conventional telephone signal generator

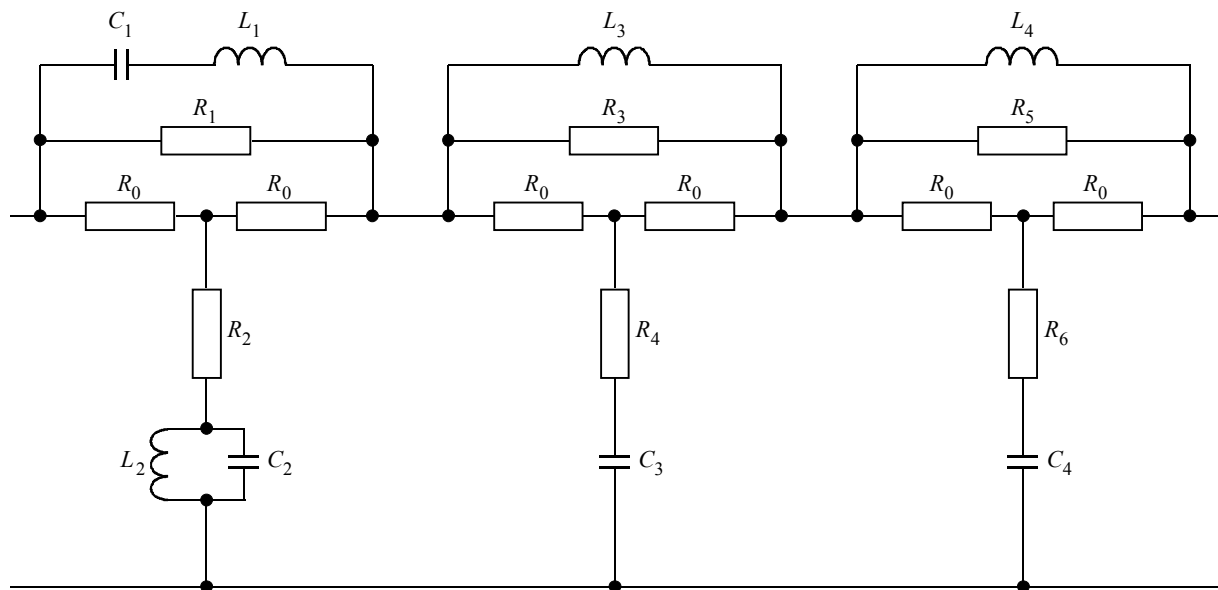

Section 1

$$\frac{R_1}{R_0} = 45$$

$$\frac{R_2}{R_0} = 0.0222$$

$$\frac{R_3}{R_0} = 10$$

$$\frac{R_4}{R_0} = 0.1$$

$$\frac{R_5}{R_0} = 22$$

$$\frac{R_6}{R_0} = 0.0455$$

Section 2

$$\frac{L_1 \omega_0}{R_0} = 0.5$$

$$\frac{L_2 \omega_0}{R_0} = 2$$

$$\frac{L_3 \omega_0}{R_0} = 0.5$$

$$\frac{L_4 \omega_0}{R_0} = 1.11$$

Section 3

$$R_0 C_1 \omega_0 = 2$$

$$R_0 C_2 \omega_0 = 0.5$$

$$R_0 C_3 \omega_0 = 0.5$$

$$R_0 C_4 \omega_0 = 1.11$$

$$\omega_0 = 2\pi \times 10^3 \times \text{s}^{-1}$$

R_0 : characteristic impedance of network

Tolerance of components: $\pm 1\%$

0328-05

5.3.3 Out-of-band spectrum

If frequency is plotted as the abscissa in logarithmic units and if the power densities are plotted as ordinates (dB) the curve representing the out-of-band spectrum should lie below two straight lines starting at point $(+0.5 F, 0 \text{ dB})$ or at point $(-0.5 F, 0 \text{ dB})$, and finishing at point $(+0.7 F, -20 \text{ dB})$ or $(-0.7 F, -20 \text{ dB})$, respectively. Beyond these points and down to the level -60 dB , this curve should lie below two straight lines starting from the latter points and having a slope of 12 dB/octave . Thereafter, the same curve should lie below the level -60 dB .

The reference level, 0 dB , corresponds to the power density that would exist if the total power, excluding the power of the carrier, were distributed uniformly over the necessary bandwidth.

5.3.4 Relationships between the 0 dB reference level for determining the out-of-band spectrum and the levels of other spectral components of the emission

5.3.4.1 Relationship between the 0 dB reference level and the level corresponding to maximum spectral power density

The 0 dB reference level defined in § 5.3.3 is about 5 dB below the level corresponding to the maximum power density in either sideband when the transmitter is modulated with white noise weighted in accordance with the curve mentioned in § 5.3.2 and shown in § 5.1.

The value of 5 dB is valid for a modulation frequency bandwidth with an upper frequency limit of 3 kHz or 3.4 kHz.

5.3.4.2 Relationship between the 0 dB reference level and the carrier level

The ratio α_B (dB) of the 0 dB reference level to the carrier level is given by the equation:

$$\alpha_B = 10 \log \left(\frac{m_{rms}^2}{2} \frac{B_{eff}}{F} \right) \quad (5)$$

where:

m_{rms} : r.m.s. modulation factor of the transmitter

B_{eff} : effective noise bandwidth of the analyser

F : necessary bandwidth for the emission.

Hence the reference level depends on:

- the power of the sideband P_s , given by the formula:

$$P_s = \frac{m_{rms}^2}{2} P_c \quad (6)$$

where P_c is the carrier power,

- the necessary bandwidth F ,
- the effective noise bandwidth B_{eff} of the analysing instrument used.

Figure 6 shows the ratio α_B calculated from equation (5) as a function of the necessary bandwidth for different values of the r.m.s. modulation factor.

For certain practical applications, for example in monitoring stations, an r.m.s. modulation factor of the transmitter of 35% may be assumed in cases where the actual modulation factor cannot be determined precisely. Equation (5) may then be simplified as follows:

$$\alpha_B = 10 \log \left(\frac{B_{eff}}{F} \right) - 12.1 \quad (7)$$

Fig. 7 shows the ratio α_B calculated from the simplified formula (7) as a function of the necessary bandwidth for different values of the effective noise bandwidth.

5.4 Single-sideband, classes of emission R3E, H3E and J3E (reduced, full or suppressed carrier) and independent-sideband class of emission B8E

5.4.1 Necessary bandwidth

For classes of emission R3E and H3E, the necessary bandwidth, F , is, in practice, equal to the value of the highest audio frequency, f_2 , which it is desired to transmit with a specified small attenuation.

For class of emission J3E, the necessary bandwidth, F , is, in practice, equal to the difference between the highest, f_2 , and lowest, f_1 , of the audio frequencies which it is desired to transmit with a specified small attenuation.

For class of emission B8E, the necessary bandwidth, F , is, in practice, equal to the difference between the two radio frequencies most remote from the assigned frequency, which correspond to the two extreme audio frequencies to be transmitted with a specified small attenuation in the two outer channels of the emission.

FIGURE 6

The ratio α_B (dB), between the 0 dB reference level for the limiting curve of the out-of-band spectrum for class of emission A3E and the level of the carrier, as a function of the necessary bandwidth F (kHz), for an effective noise bandwidth of the analysing instrument of 100 Hz with the r.m.s. modulation factor (m_{rms}) of the transmitter as a parameter

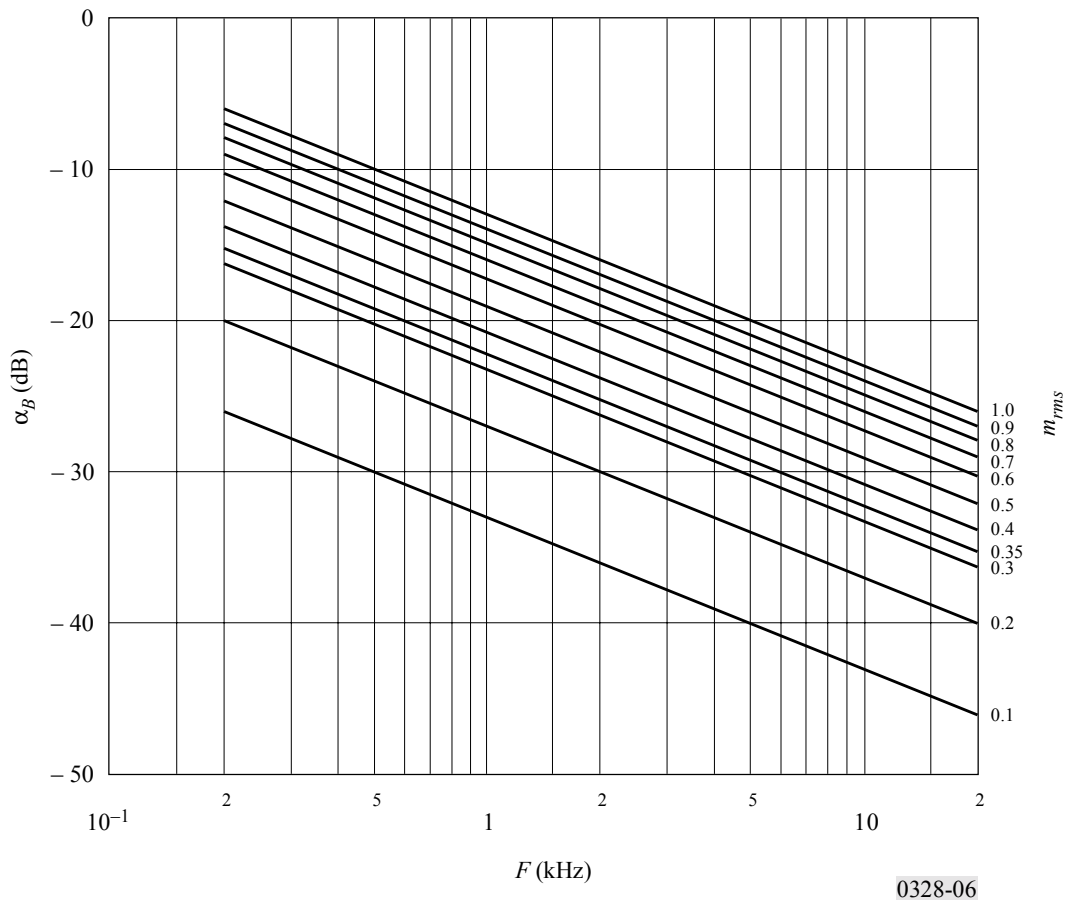

5.4.2 Power within the necessary band

For considerations with regard to the power in the necessary band, reference is made to § 5.3.2.

5.4.3 Out-of-band spectrum for class of emission B8E; four telephony channels simultaneously active

The out-of-band power is dependent on the number and position of the active channels. The text below is only appropriate when four telephone channels are active simultaneously. When some channels are idle, the out-of-band power is less.

If frequency is plotted as the abscissa in logarithmic units, the reference frequency being supposed to coincide with the centre of the necessary band, and if the power densities are plotted as ordinates (dB) the curve representing the out-of-band spectrum should lie below two straight lines starting at point $(+0.5 F, 0 \text{ dB})$ or at point $(-0.5 F, 0 \text{ dB})$ and finishing at point $(+0.7 F, -30 \text{ dB})$ or $(-0.7 F, -30 \text{ dB})$ respectively. Beyond the latter points and down to the level -60 dB , this curve should lie below two straight lines starting from the latter points and having a slope of 12 dB/octave . Thereafter, the same curve should lie below the level -60 dB .

The reference level, 0 dB , corresponds to the power density that would exist if the total power, excluding the power of the reduced carrier, were distributed uniformly over the necessary bandwidth.

FIGURE 7

The ratio α_B (dB), between 0 dB reference level for the limiting curve of the out-of-band spectrum for class of emission A3E and the level of the carrier as a function of the necessary bandwidth F (kHz), for an r.m.s. modulation factor of 35% with the effective noise bandwidth (B_{eff}) of the analysing instrument as a parameter

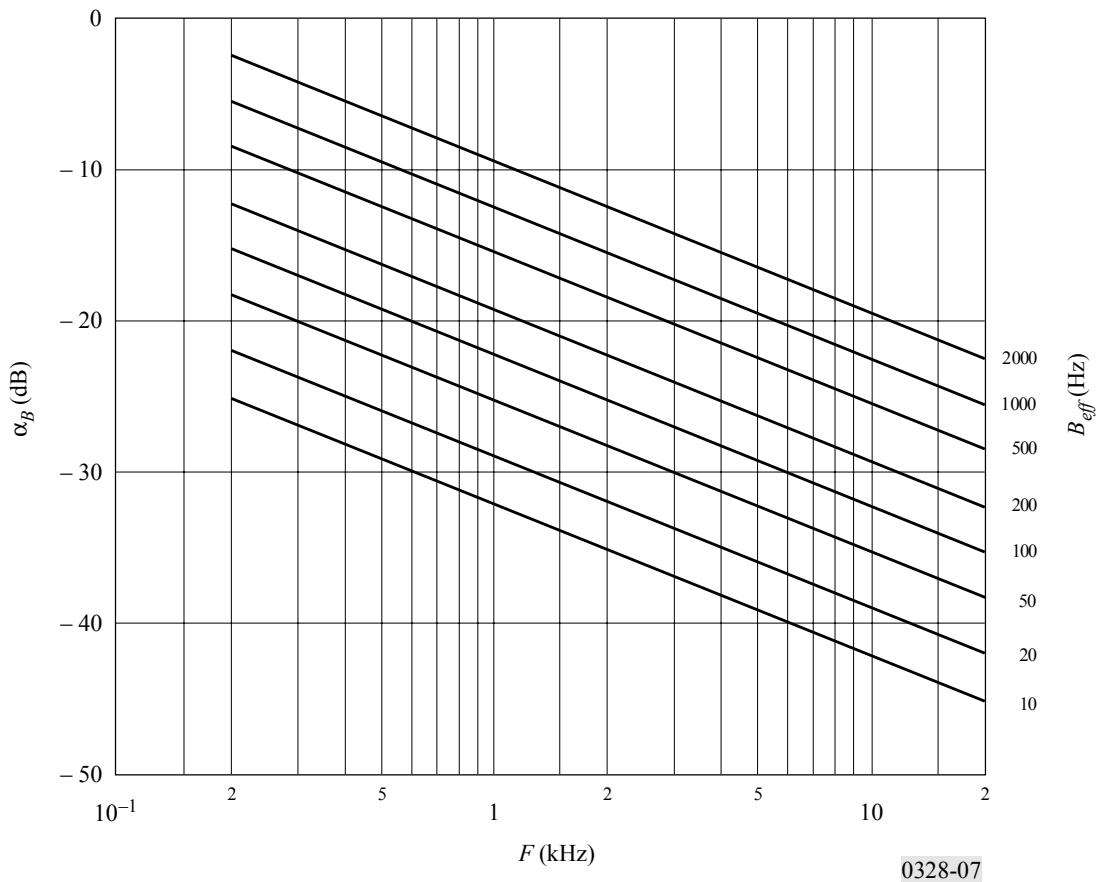

6 Amplitude-modulated emissions for sound broadcasting

The spectrum limits described in this section for amplitude-modulated emissions for sound broadcasting have been deduced from measurements performed on transmitters which were modulated by weighted noise to an r.m.s. modulation factor of 35% in the absence of any dynamic compression of the signal amplitudes.

6.1 Type of modulation signal and adjustment of the input signal level, class of emission A3EGN, sound broadcasting

The adjustment procedure described in § 5.1 above may also be applied to transmitters for sound broadcasting, except that in this case, the noise is weighted in accordance with the curves mentioned in § 6.3.2, and shown in Fig. 8.

6.2 Noise signal for modulating the signal generators (extract from Recommendation ITU-R BS.559, § 1.3)

Two conditions should be fulfilled by the standardized signal to simulate programme modulation:

- its spectral constitution must correspond to that of a representative broadcast programme;
- its dynamic range must be small to result in a constant unequivocal reading on the instrument.

FIGURE 8

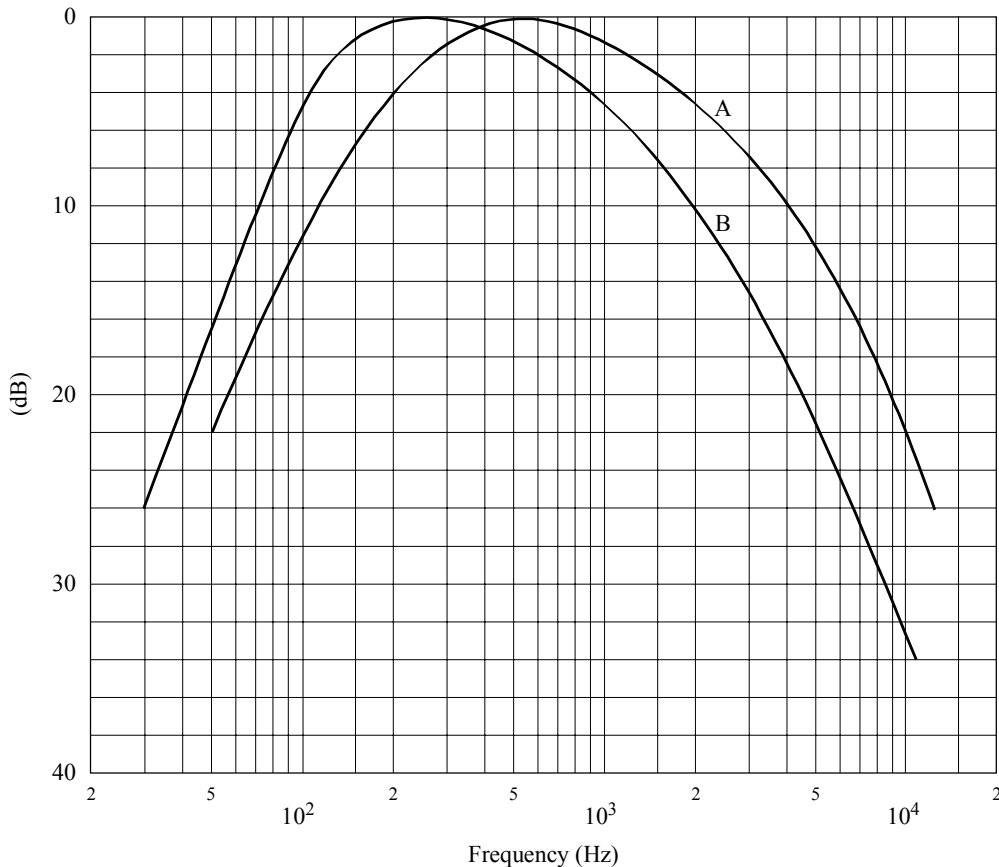

Curves A: frequency spectrum of standardized noise (measured with one-third octave filters)
 B: frequency response characteristic of filter-circuit

0328-08

The amplitude distribution of modern dance music was taken as a basis, as it is a type of programme with a considerable proportion of high audio-frequencies, which occur most frequently. However, the dynamic range of this type of programme is too wide and does not fulfil, therefore, the second requirement mentioned above. A signal which is appropriate for this purpose is a standardized coloured noise signal, the spectral amplitude distribution of which is fairly close to that of modern dance music (see curve A of Fig. 8, which is measured using one-third octave filters).

This standardized coloured noise signal may be obtained from a white-noise generator by means of a passive filter circuit as shown in Fig. 9. The frequency-response characteristic of this filter is reproduced as curve B of Fig. 8. (It should be noted that the difference between curves A and B of Fig. 8 is due to the fact that curve A is based on measurements with one-third octave filters which pass greater amounts of energy as the bandwidth of the filter increases with frequency.)

The spectrum beyond the required bandwidth of the standardized coloured noise should be restricted by a low-pass filter having a cut-off frequency and a slope such that the bandwidth of the modulating signal is approximately equal to half the standardized bandwidth of emission. The audio-frequency amplitude/frequency characteristic of the modulating stage of the signal generator shall not vary by more than 2 dB up to the cut-off frequency of the low-pass filter.

6.3 Class of emission A3E, double-sideband sound broadcasting

6.3.1 Necessary bandwidth

The necessary bandwidth, F , is in practice equal to twice the highest modulation frequency, M , which it is desired to transmit with a specified small attenuation.

FIGURE 9
Filter circuit

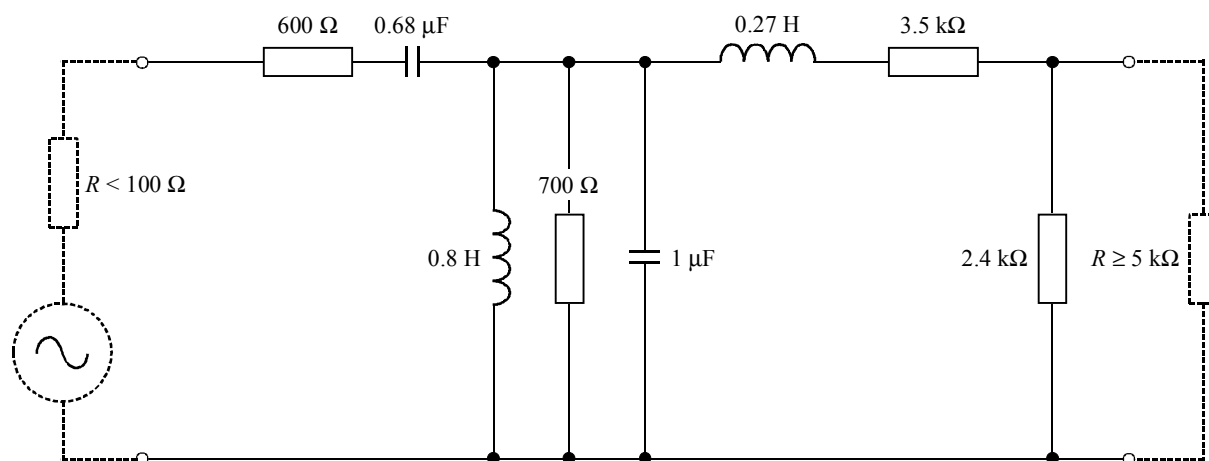

0328-09

6.3.2 Power within the necessary band

The statistical distribution of power within the necessary band is determined by the relative power level of the different audio-frequency components applied at the input to the transmitter.

The power distribution in the audio-frequency band of an average broadcast programme can be assumed to correspond to the curves given in Fig. 8. In practice, these curves will not be exceeded for more than 5% to 10% of the programme transmission time.

6.3.3 Out-of-band spectrum

If frequency is plotted as the abscissa in logarithmic units and if the power densities are plotted as ordinates (dB) the curve representing the out-of-band spectrum should lie below two straight lines starting at point $(+0.5 F, 0 \text{ dB})$ or at point $(-0.5 F, 0 \text{ dB})$ and finishing at point $(+0.7 F, -35 \text{ dB})$ or $(-0.7 F, -35 \text{ dB})$ respectively. Beyond these points and down to the level of -60 dB , this curve should lie below two straight lines starting from the latter points and having a slope of 12 dB/octave . Thereafter, the same curve should lie below the level -60 dB .

The reference level, 0 dB , corresponds to the power density that would exist if the total power, excluding the power of the carrier, were distributed uniformly over the necessary bandwidth (see § 6.3.4).

The ordinate of the curve so defined represents the average power intercepted by an analyser with an r.m.s. noise bandwidth of 100 Hz , the frequency of which is tuned to the frequency plotted on the abscissa.

6.3.4 Relationship between the 0 dB reference level for determining the out-of-band spectrum and the levels of other spectral components of the emission

6.3.4.1 Relationship between the 0 dB reference level and the level corresponding to maximum spectral power density

The 0 dB reference level defined in § 6.3.3 is $8\text{--}10 \text{ dB}$ below the level corresponding to the maximum power density in either sideband when the transmitter is modulated with white noise weighted in accordance with the curves mentioned in § 6.3.2.

The value of 8 dB is valid for a modulation frequency bandwidth with an upper frequency limit of 4.5 kHz or 6 kHz . The value of 10 dB is applicable when the upper frequency limit is 10 kHz .

6.3.4.2 Relationship between the 0 dB reference level and the carrier level

See § 5.3.4.2, which is also applicable in this case of sound broadcasting.

Considerations for emissions designated Types B and R

(Independent sideband and single sideband)

TABLE OF CONTENTS

		<i>Page</i>
1	Shape of the spectrum envelope for class B8E and class R7J emissions modulated with white noise.....	20
1.1	The tests described in item 1 of Table 3.....	21
1.2	The tests described in item 2 of Table 3.....	22
1.3	The tests described in item 3 of Table 3.....	22

1 Shape of the spectrum envelope for class B8E and class R7J emissions modulated with white noise

This section deals with the results of measurements made by several administrations on transmitters of different design for classes of emission B8E and R7J.

The major characteristics of the transmitters and the test condition relating to the measurements are summarized in Table 3.

TABLE 3

Transmitter characteristics and measurement test conditions for B8E and R7J emissions

Item No.	1	2	3
Class of emission	B8E	B8E	B8E; R7J
<i>Transmitter characteristics:</i>		Various transmitters Several kW up to some tens of kW	Various transmitters Different values
– peak envelope power P_p (two tones) ⁽¹⁾ (kW)	20		
– third order intermodulation distortion $\alpha_3^{(1)}$ (dB)	≤ -35		
– number of channels active during the measurement	2, in lower sideband	2 and 4	
– bandwidth of speech channel (Hz)	3 000		
– carrier suppression (dB) relative to peak envelope power	–50		
<i>Type of modulating signal:</i>		White noise	White noise
– bandwidth	White noise 30 Hz-20 kHz ± 1 dB		100 Hz-6 kHz per sideband

TABLE 3 (end)

Item No.	1	2	3
Class of emission	B8E	B8E	B8E; R7J
<i>Input signal level</i> ⁽¹⁾ adjusted to a value such that: – at the output, P_m (noise) =	0.25 P_p (two tones)		0.25 P_p (two tones)
<i>Type of measuring device:</i> – passband (Hz)	True r.m.s. selective measurement device Curves C: 3 800 D: 100	Spectrum analyser $\leq 0.05 F^{(2)}$	Spectrum analyser
Shape of spectrum	See Fig. 10	See § 1.1	

⁽¹⁾ In all tests, the transmitter is first modulated with two sinusoidal signals of equal amplitude. Next, the peak envelope power, P_p (two tones), and the third order intermodulation distortion level, α_3 , are determined in accordance with the methods given in Recommendation ITU-R SM.326. Finally, the two sinusoidal signals are replaced by a noise signal, the level of which is adjusted to obtain one of the conditions mentioned under “input signal level”, where P_m denotes mean power and P_p denotes peak envelope power.

⁽²⁾ B_p is the passband resulting from the filters in the transmitter, and F is the necessary bandwidth.

The results of the measurements may be summarized as follows:

1.1 The tests described in item 1 of Table 3

Only the lower sideband was used, the upper sideband being suppressed to at least -60 dB by means of the filter incorporated in the transmitter. The carrier was suppressed to approximately -50 dB (class J3E) and the audio-frequency bandwidth was approximately 6 000 Hz.

The bandwidth of the noise signal was limited only by the filter characteristic of the transmitter (see curve A of Fig. 10). In this connection it should be noted that, if the radio-frequency spectrum produced by only one speech channel were to be determined, the bandwidth of the test signal should be limited before it is applied to the transmitter, since its overall bandwidth is considerably larger than the width of one speech channel.

One series of measurements was carried out using an analyser with a bandwidth of about 100 Hz. An analyser with a bandwidth of 3.8 kHz and a very steep attenuation slope was employed for the other series.

The results are shown in Fig. 10 curves D and C respectively. These curves represent the envelopes of the spectra of the lower sideband, measured in the lower radio-frequency range. Curves similar to those given in Fig. 10 were obtained for the higher frequency range.

If the spectrum measured with the aid of narrow-band equipment is, as in the present case, just within the limiting curve B, the spectrum analysed by means of wideband receivers will exceed this limit. As wideband measuring equipment does not take account of the fine structure of the spectrum, particularly in the region where its slope is steep, the use of narrow-band devices for such measurements is recommended.

It can be further concluded from Fig. 10 that the out-of-band radiation starts at a level nearly equal to the level of third order intermodulation components, viz. at -35 dB. The out-of-band radiation remains almost constant in the immediate vicinity of the limits of the bandwidth; for frequencies remote from these limits the curve gradually decays, at first proportional to frequency, then reaching an ultimate slope of about 12 dB/octave. In Fig. 11 a linear frequency scale has been used at the abscissa to illustrate more clearly the envelope of the spectrum mentioned above.

FIGURE 10

Envelope of power density spectrum for class of emission B8E

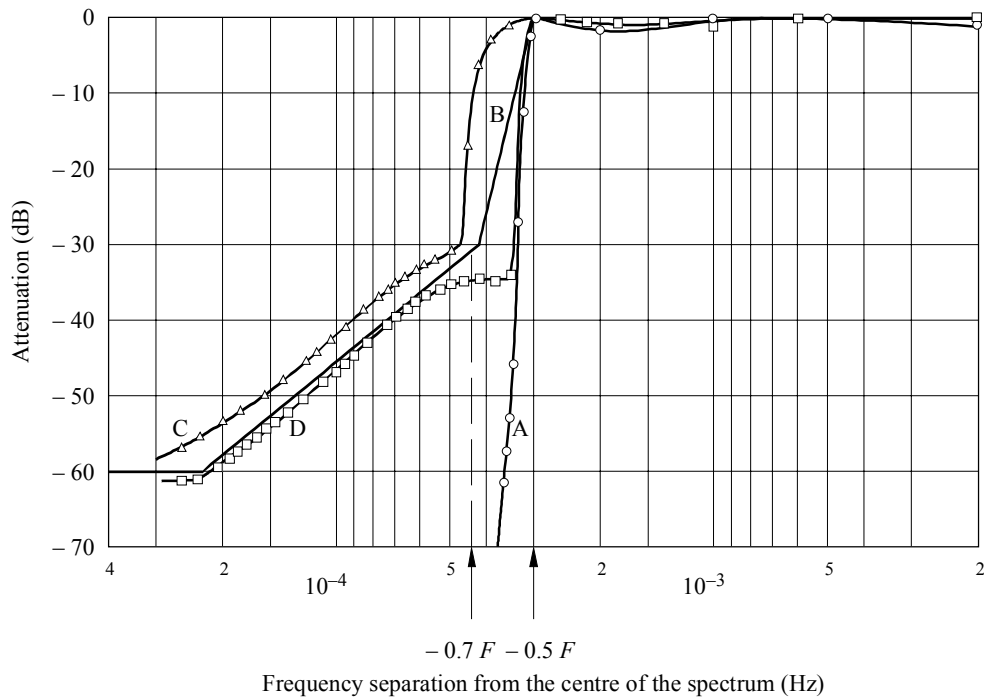

F : necessary bandwidth (6 000 Hz)

- Curves A: filter characteristic of the transmitter
 B: limiting curve specified in § 5.4.3 of Annex 1
 C: measured with an analyser having a passband of 3 800 Hz
 D: measured with an analyser having a passband of about 100 Hz

0328-10

1.2 The tests described in item 2 of Table 3

If frequency is plotted as the abscissa in logarithmic units, the reference frequency being assumed to coincide with the centre of the necessary bandwidth F , and if the power densities are plotted as ordinates (dB) the curves representing the out-of-band spectra produced by a number of transmitters of different power rating for class of emission B8E (two channels or four channels simultaneously active) lie below two straight lines starting at point $(+0.5 F, 0 \text{ dB})$ or at point $(-0.5 F, 0 \text{ dB})$, and finishing at point $(+0.55 F, -30 \text{ dB})$ or $(-0.55 F, -30 \text{ dB})$, respectively. Beyond the latter points and down to the level -60 dB , the curves lie below two straight lines starting from the latter points and having a slope of 12 dB/octave .

1.3 The tests described in item 3 of Table 3

The test equipment was arranged to facilitate intermodulation distortion measurements to be made either by the two-tone method or the white-noise method, so that comparisons could be made between the two methods. When using the white-noise method, the white noise generator output was passed through filters to limit the noise bandwidth to the maximum bandwidth normally expected on traffic i.e. $100\text{--}6\,000 \text{ Hz}$ per sideband. A band stop filter provided a slot in which “in-band” distortion products could be measured using a 30 Hz filter in the spectrum analyser. A band-stop filter with a minimum bandwidth of 500 Hz at 3 dB and a 60 dB shape factor of 3.5 to 1 was found necessary to permit adequate resolution by the 30 Hz spectrum analyser filter when measuring distortion ratios approaching 50 dB .

FIGURE 11
Curve D of Fig. 10 shown on a linear frequency scale

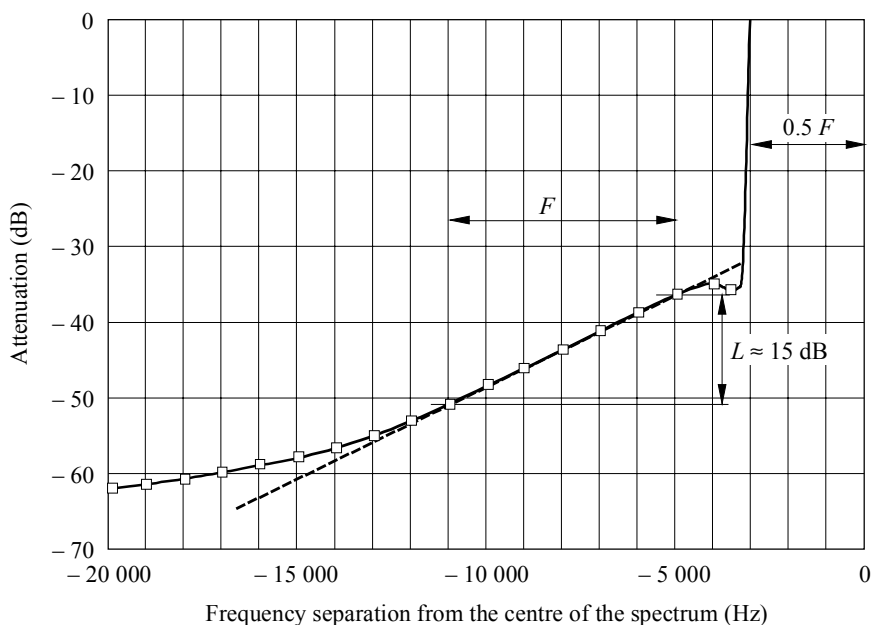

L: linear region equal to about the necessary bandwidth *F*

0328-11

The majority of the white-noise loading tests were made with a mean output power level of -6 dB relative to peak envelope power rating which confirms the relationship mentioned in Annex 5 § 1.2.4, equation (16).

The tests confirm and extend the earlier conclusions and establish the use of a white-noise signal as a valid substitute for the modulating signal of two types of multiplex emissions, B8E and R7E, in common use. Further, the tests disclose a useful and stable experimental relationship between in-band intermodulation distortion and out-of-band radiation. However, there was no clear agreement between two-tone intermodulation distortion ratios and equivalent white-noise loading distortion.

ANNEX 3

Considerations for emissions designated Type F
(Frequency modulation)

TABLE OF CONTENTS

	<i>Page</i>
1 Class of emission F1B	24
1.1 Necessary bandwidth	24
1.2 Shape of the spectrum envelope.....	24
1.2.1 Telegraph signal consisting of reversals with zero build-up time	24
1.2.2 Periodic telegraph signals with finite build-up time.....	26
1.2.3 Non-periodic telegraph signal with finite build-up time.....	27

1.3	Out-of-band power and occupied bandwidth	28
1.4	Shaping of the telegraph signal by means of filters	30
1.5	Adjacent-channel interference.....	30
1.6	Build-up time of the signal.....	30
1.7	Bandwidth occupied, for unshaped signals	30
1.8	Out-of-band spectrum	30
2	Frequency-modulated emissions for sound broadcasting and radiocommunications	31
2.1	Class of emission F3E, monophonic sound broadcasting	31
2.1.1	Necessary bandwidth.....	31
2.1.2	Out-of-band spectrum of class F3E emissions modulated by noise	31
2.2	Classes of emission F8E and F9E, stereophonic sound broadcasting	31
2.2.1	Necessary bandwidth.....	31
2.3	Class of emission F3E, narrow-band radiocommunications	31
3	Frequency-modulated multi-channel emissions employing frequency division multiplex (FDM)	32
3.1	Necessary bandwidth	32
3.2	Shape of the spectrum envelope.....	32
3.3	Out-of-band power.....	35

1 Class of emission F1B

For class of emission F1B, frequency-shift telegraphy, with or without fluctuations due to propagation:

1.1 Necessary bandwidth

If the frequency shift, or the difference between mark and space frequencies is $2D$ and if m is the modulation index, $2D/B$, the necessary bandwidth is given by one of the following formulae, the choice depending on the value of m :

$$\begin{aligned} 2.6D + 0.55B & \quad \text{within 10\% for } 1.5 < m < 5.5 \\ 2.1D + 1.9B & \quad \text{within 2\% for } 5.5 \leq m \leq 20 \end{aligned}$$

1.2 Shape of the spectrum envelope

The shape of the RF spectrum for class of emission F1B is described in § 1.2.1 to 1.2.3 below for various shapes of the telegraph signal.

1.2.1 Telegraph signal consisting of reversals with zero build-up time

The amplitude of the spectrum envelope relative to the amplitude of the continuous emission, $A(n)$, is shown in Fig. 12 (solid lines) as a function of the order of the sideband component for a telegraph signal consisting of reversals with zero build-up time and equal mark and space durations.

The linear or asymptotic parts of the solid curves shown in Fig. 12 may be approximated with the aid of the formula:

$$A(n) = \frac{2m}{\pi n^2} \quad (8)$$

where:

n : order of the sideband component

$$n = 2f/B$$

f : rate (Bd)

m : modulation index frequency separation from the centre of the spectrum (Hz)

B : modulation

$$m = 2D/B$$

D : peak frequency deviation or half the frequency shift (Hz).

FIGURE 12
Envelopes of RF spectra for a telegraph signal consisting of reversals

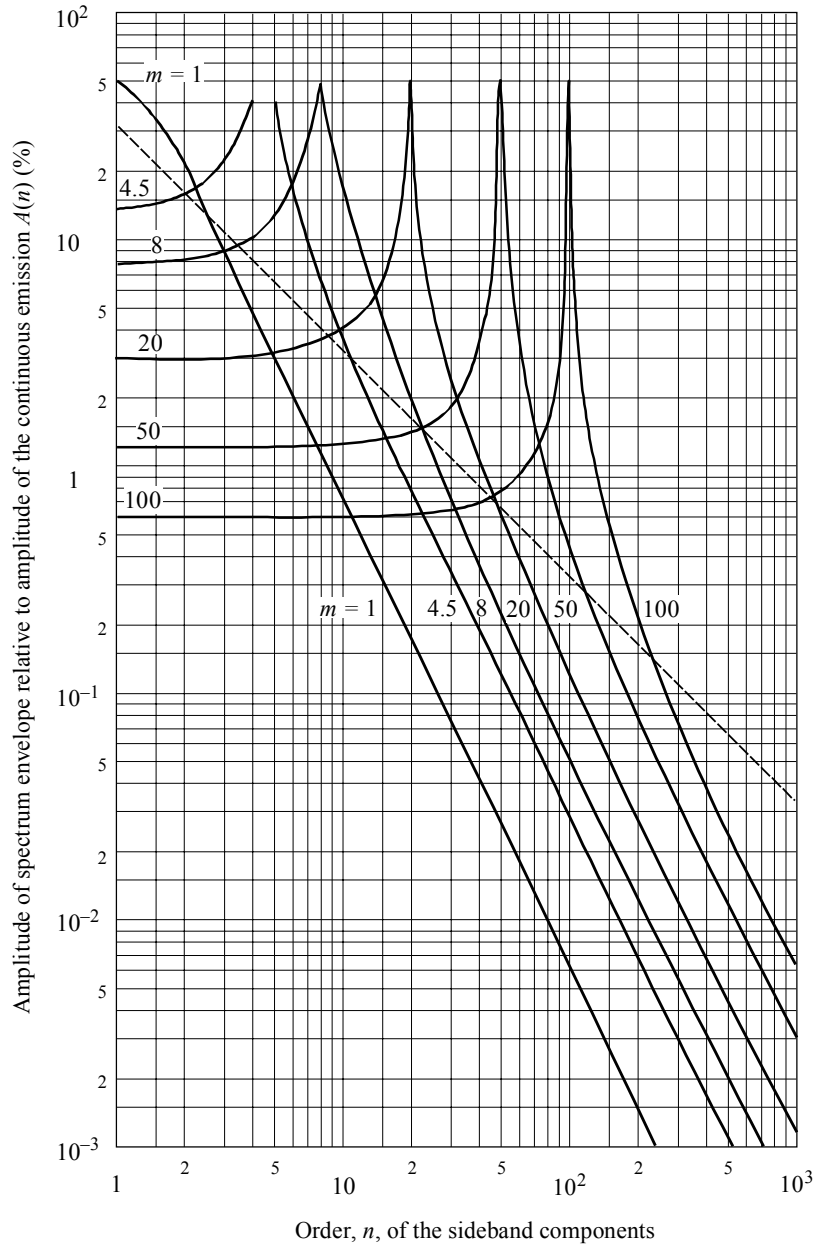

m : modulation index
 ——— Class of emission F1B
 - - - - - Classes of emission A1A and A1B

1.2.2 Periodic telegraph signals with finite build-up time

The amplitude, $A(x)$ of the envelope of the spectrum produced by a telegraph signal consisting of reversals with a finite build-up time and equal mark and space durations is given by the following empirical formula:

$$A(x) = E \frac{2}{\pi} \frac{1}{m} x^{-u} (x^2 - 1)^{-1} \quad \text{for } x > 1 \quad (9)$$

where:

$$x = f/D$$

E : amplitude of the continuous emission

$$u = \sqrt{5 D \tau}$$

τ : build-up time of signal(s) of the telegraph signal, as defined in *recommends* 1.20

f, D, m : as defined in § 1.2.1 above.

In equation (9), the shape of the spectrum envelope depends only on the product $D \tau$ and that for a given value of this product the amplitude, $A(x)$, of the envelope is inversely proportional to the modulation index m . This is illustrated in Fig. 13, where the product $m A(x)$ is shown as a function of x for various values of $D \tau$.

FIGURE 13
Spectrum distribution of F1B emission calculated from the empirical formula (9)

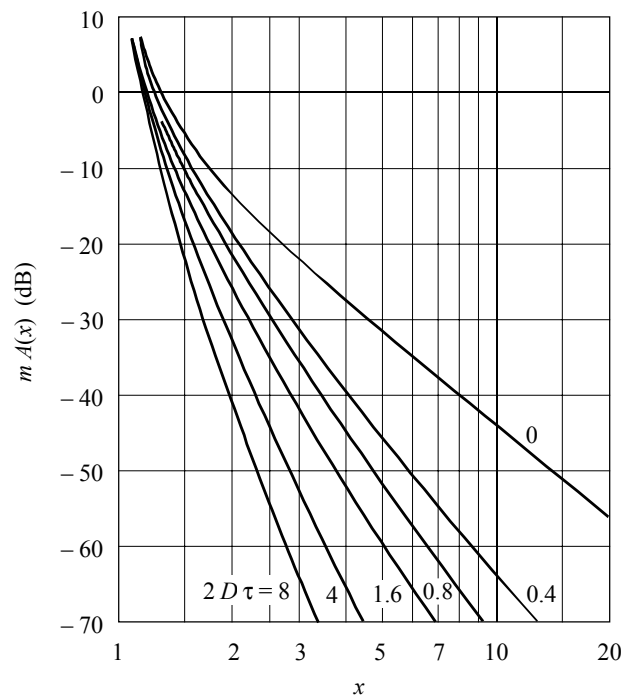

0328-13

It has been shown that the effect of the build-up time on the shape of the spectrum envelope is small for values of $D \tau$ which are less than 0.15 or are between 1 and 5. When the mark and space durations are unequal, the shape of the spectrum envelope depends largely on the product of $D \tau$ and the duration of the shortest signal element, but is always similar to that produced by a signal consisting of reversals with the same build-up time.

In Fig. 14 the results of measurements made on various spectra are compared with those obtained by calculating the corresponding values from equation (9). The agreement is satisfactory for values of x greater than 1.2, but decreases for decreasing values of the product $D \tau$.

FIGURE 14
Spectra of F1B emissions

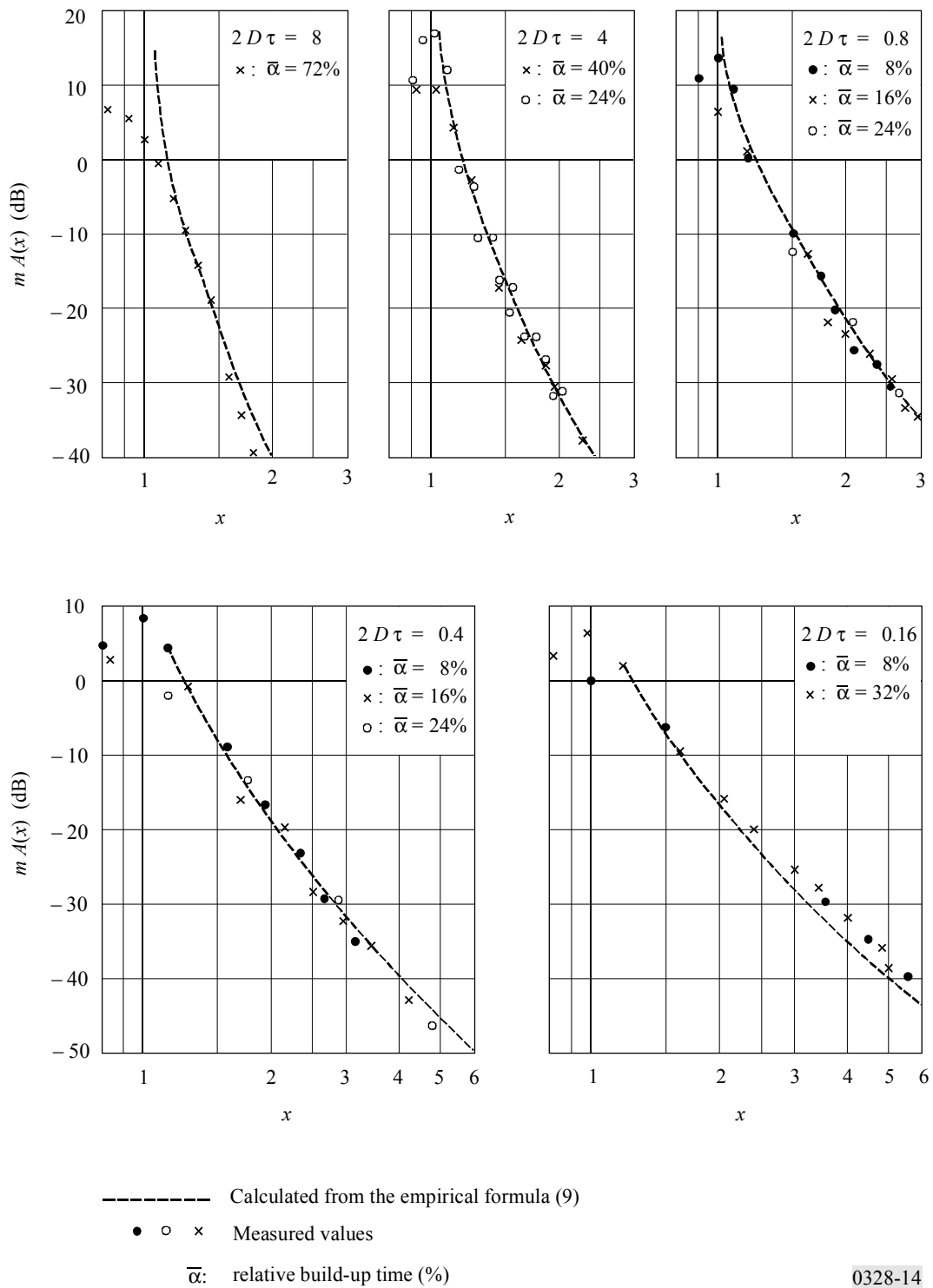

0328-14

1.2.3 Non-periodic telegraph signal with finite build-up time

When the signal is non-periodic, as may be the case under actual traffic conditions, the spectrum distribution should be represented in the form of a power density spectrum.

The average power density per unit of bandwidth, $p(x)$, is given by the empirical formula:

$$p(x) = \frac{P_0}{B} \frac{4}{\pi^2} \frac{1}{m^2} x^{-2u} (x^2 - 1)^{-2} \tag{10}$$

where:

- P_0 : total power of the emission
- B, m, x, u : as defined in § 1.2.1 and 1.2.2.

Also in this case, the shape of the spectrum envelope depends only on the product of frequency shift and build-up time.

1.3 Out-of-band power and occupied bandwidth

The out-of-band power, P' , as defined in *recommends* 1.11 may be determined by integrating the power density given by equation (10) between two frequency limits.

Fig. 15 shows the values of bandwidth, L , calculated in terms of m and $2 D \tau$, for $\beta = 0.01$ and $\beta = 0.001$, where β is the out-of-band power ratio P'/P_0 .

FIGURE 15
Bandwidth calculation from the empirical formula (10)

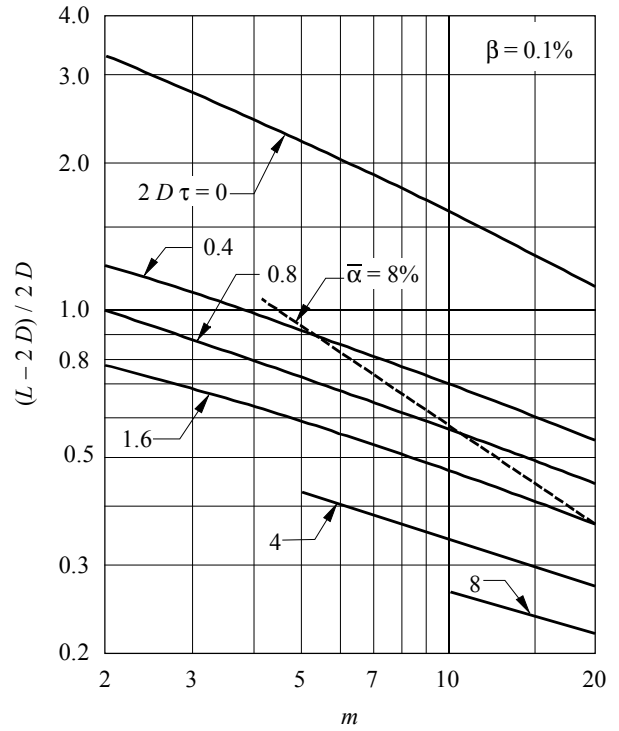
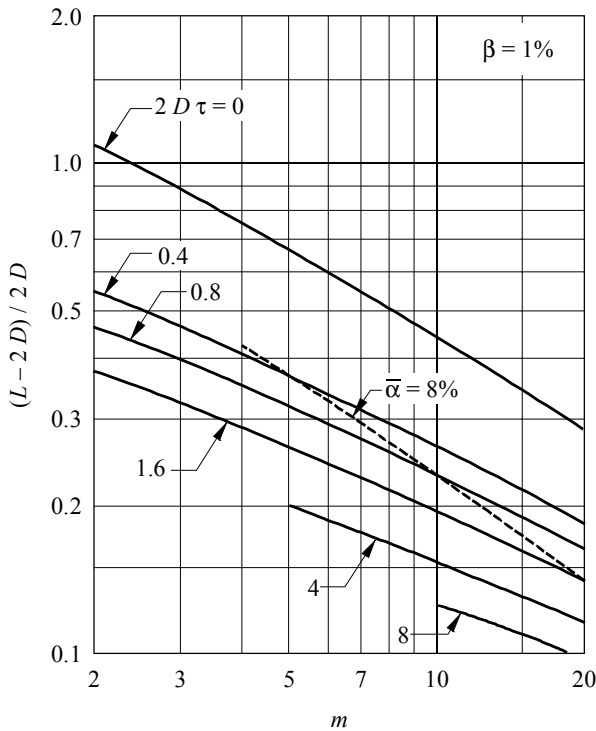
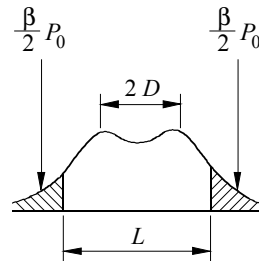

The occupied bandwidth L (Hz) for $\beta = 0.01$ may also be calculated from the empirical equation:

$$L = 2D + D(3 - 4\sqrt{\bar{\alpha}})m^{-0.6} \tag{11}$$

where $\bar{\alpha}$ is the relative build-up time of the shortest pulse of the telegraph signal, as defined in *recommends* 1.21.

The occupied bandwidth so calculated is hardly affected by the shape of the telegraph signal, whereas the out-of-band spectrum depends largely on this shape.

The maximum divergence between the results obtained by using equation (11) and those obtained by exact calculations, is as follows:

- 3% for $\bar{\alpha} = 0$; $2 \leq m \leq 20$
- 9% for $\bar{\alpha} = 0.08$; $1.4 \leq m \leq 20$
- 10% for $\bar{\alpha} = 0.24$; $2 \leq m \leq 20$.

The list above shows the limits within which equation (11) can be used with reasonable accuracy. The percentages indicated apply to the lower limit of m . They are less for the higher limit.

Finally, Fig. 16 shows the results of calculations and measurements of occupied bandwidth employing different methods.

FIGURE 16
Comparison of the results of calculations and measurements
of occupied bandwidth

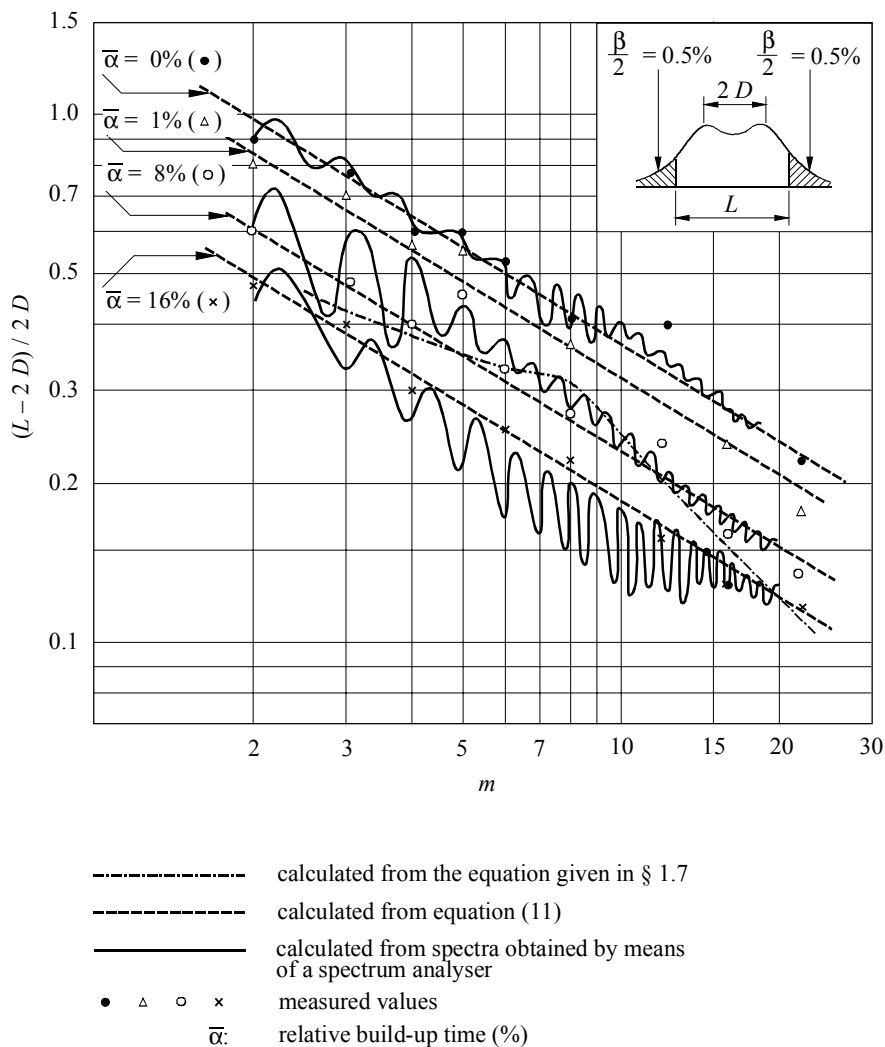

1.4 Shaping of the telegraph signal by means of filters

See Annex 1, § 3. However, the use of minimum overshoot filters is not essential, when the transmitter is required to operate at more than two frequencies, for example in the case of four-frequency duplex.

1.5 Adjacent-channel interference

See Annex 1, § 1.6.

1.6 Build-up time of the signal

An out-of-band spectrum close to the limiting curve described in § 1.8 corresponds to a build-up time equal to about 8% of the initial duration of the telegraph dot, i.e. about $1/12 B$, provided that an adequate filter is used for signal shaping.

1.7 Bandwidth occupied, for unshaped signals

For the purpose of comparison with the formulae in § 1.1, it may be mentioned that, for a sequence of equal and rectangular (zero build-up time) mark and space signals, the occupied bandwidth is given by the following formulae:

$$\begin{aligned} 2.6 D + 1.4 B & \quad \text{within 2\% for } 2 \leq m \leq 8 \\ 2.2 D + 3.1 B & \quad \text{within 2\% for } 8 \leq m \leq 20. \end{aligned}$$

1.8 Out-of-band spectrum

If frequency is plotted as the abscissa in logarithmic units and if the power densities are plotted as ordinates (dB), the curve representing the out-of-band spectrum should lie below two straight lines of constant slope in decibels per octave, starting from the two points situated at the frequencies limiting the necessary bandwidth, and finishing at the level -60 dB. Thereafter, the same curve should lie below the level -60 dB. The starting ordinates of the two straight lines and their slopes are given in Table 4, as a function of the modulation index, m .

TABLE 4

Modulation index	Starting ordinates (dB)	Slope (dB/octave)
$1.5 \leq m < 6$	-15	$13 + 1.8 m$
$6 \leq m < 8$	-18	$19 + 0.8 m$
$8 \leq m \leq 20$	-20	$19 + 0.8 m$

The reference level, 0 dB, corresponds to the mean power of the emission.

The permissible amounts of out-of-band power, above and below the frequency limits of the necessary bandwidth, are each approximately 0.5% of the total mean power radiated.

The curve representing the out-of-band spectrum for modulation indexes $0.5 \leq m \leq 1.5$ should lie below the points with the coordinates given in Table 5.

TABLE 5

Formula for calculating B_x at levels X (dB)				
-20	-30	-40	-50	-60
$3 \sqrt{m} \cdot B$	$4.1 \sqrt{m} \cdot B$	$5.8 \sqrt{m} \cdot B$	$8.1 \sqrt{m} \cdot B$	$11 \sqrt{m} \cdot B$

m : modulation index

B : modulation rate.

For each point of the limiting spectrum curve, the abscissa is the relative bandwidth $\pm B_x/2 B$, and the ordinate is the relative level X . The reference level 0 dB is the level of the unmodulated carrier.

2 Frequency-modulated emissions for sound broadcasting and radiocommunications

2.1 Class of emission F3E, monophonic sound broadcasting

2.1.1 Necessary bandwidth

The necessary bandwidth can be calculated by the formula, provided in Recommendation ITU-R SM.1138:

$$B_n = 2 M + 2 D K \quad (12)$$

where:

- B_n : necessary bandwidth
- M : highest modulation frequency
- D : maximum deviation of the RF carrier
- K : factor, equals 1 if the condition $D \gg M$ is met.

2.1.2 Out-of-band spectrum of class F3E emissions modulated by noise

The curve representing the out-of-band spectrum should lie below the points with the coordinates given in Table 6.

TABLE 6

Formula for calculating B_x at levels X (dB)					Effective modulation index m'
-20	-30	-40	-50	-60	
$6 m' M$	$(6.7 m' + 2) M$	$(7.8 m' + 3) M$	$(8.4 m' + 4.4) M$	$(9 m' + 6) M$	$0.5 \leq m' \leq 1.3$
$6 m' M$	$(7 m' + 2) M$	$(7.8 m' + 4) M$	$(8.4 m' + 6) M$	$(8.8 m' + 8) M$	$m' > 1.3$

$m' = D/pM$: effective modulation index

D : peak frequency deviation

p : peak factor

M : maximum modulation frequency.

For each point of the limiting spectrum curve the abscissa is the relative bandwidth $\pm B_x/2 M$, and the ordinate is the relative level X . The reference level 0 dB is the level of the maximum spectral power density within a sideband.

2.2 Classes of emission F8E and F9E, stereophonic sound broadcasting

2.2.1 Necessary bandwidth

The necessary bandwidth can be calculated by equation (12), provided in Recommendation ITU-R SM.1138.

2.3 Class of emission F3E, narrow-band radiocommunications

Narrow-band FM is used for communication purposes. The basic spectrum requirement is given by equation (12), but pre-emphasis requirements vary widely and it is impracticable to specify particular parameters.

3 Frequency-modulated multi-channel emissions employing frequency division multiplex (FDM)

The output signal of a frequency-modulated multi-channel transmitter using FDM can be simulated by a signal which is frequency-modulated with white noise. This applies also to the output signal of a transmitter with a limited number of channels if band-splitting privacy devices are used in each of the channels.

This section presents results of a theoretical analysis of the spectrum of a signal which is frequency-modulated with white noise, for various degrees of frequency deviation. The results have been confirmed by measurements of actual spectra.

Emissions with modulation indices which are neither very large nor very small are important in actual communication systems.

3.1 Necessary bandwidth

See Recommendation ITU-R SM.853 (Necessary bandwidth), § 1: (Multi-channel frequency division multiplex – frequency modulation (FDM-FM) emissions).

3.2 Shape of the spectrum envelope

The power spectrum, $p(f)$, of a signal which is frequency modulated with white noise can be calculated as follows, taking into account the effects of pre-emphasis specified in Recommendation ITU-R F.275. This calculation is based on Fourier transform of the autocorrelation function of the modulating phase signal.

$$R_s(\tau) = \frac{2\sigma^2}{f_{max}^2} \int_{\varepsilon}^1 \frac{\sin^2(\pi f_{max} \tau u)}{u^2} P_r(u) du \quad (13)$$

where:

f_{max} : highest modulating frequency

f_{min} : lowest modulating frequency

$$\varepsilon = f_{min}/f_{max}$$

σ : r.m.s. multi-channel frequency deviation

$P_r(u)$: pre-emphasis characteristic.

$$P_r(f/f_{max}) = C_0 + C_2 (f/f_{max})^2 + C_4 (f/f_{max})^4$$

$$C_0 = 0.4, C_2 = 1.35, C_4 = 0.75 \text{ (see Recommendation ITU-R SF.675)}$$

$$p(f) = 2P_0 \int_0^{\infty} \exp[-R_s(\tau)] \cos(2\pi f \tau) d\tau \quad (14)$$

where P_0 is the total power.

When σ is very large, the value of equation (14) is dominated by small τ . In this case, approximately $R_s(\tau) = 2(\pi \sigma \tau)^2$. Therefore, the envelope of the spectrum can be approximated by the following Gaussian distribution:

$$p(f) = \frac{P_0}{\sqrt{2\pi} \sigma} \exp\left(-\frac{f^2}{2\sigma^2}\right) \quad (15)$$

Theoretical calculations of the envelope of spectrum were carried out for various modulation indices. Curves for $\sigma/f_{max} \geq 0.5$ are presented in Fig. 17 and those for $\sigma/f_{max} < 0.5$ are presented in Fig. 18. These curves are based on the assumption of $\varepsilon = 0$. In actual applications, ε is not zero. In this case, there appears a discrete component at the carrier frequency, because at large τ , $R_s(\tau)$ calculated by equation (13) does not become infinite, while if $\varepsilon = 0$, it becomes

infinite. This residual carrier generally becomes larger at smaller modulation index (see Recommendation ITU-R SF.675). Therefore, in Fig. 18, the shape of power spectrum near the carrier and at integral multiples of f_{max} may be somewhat different. However, the effect of the assumption of $\epsilon = 0$ on the out-of-band power (Figs. 19 and 20) is not significant. Recommendation ITU-R SF.766 presents various power spectra in actual applications.

FIGURE 17
Power spectral distribution for $\sigma/f_{max} \geq 0.5$

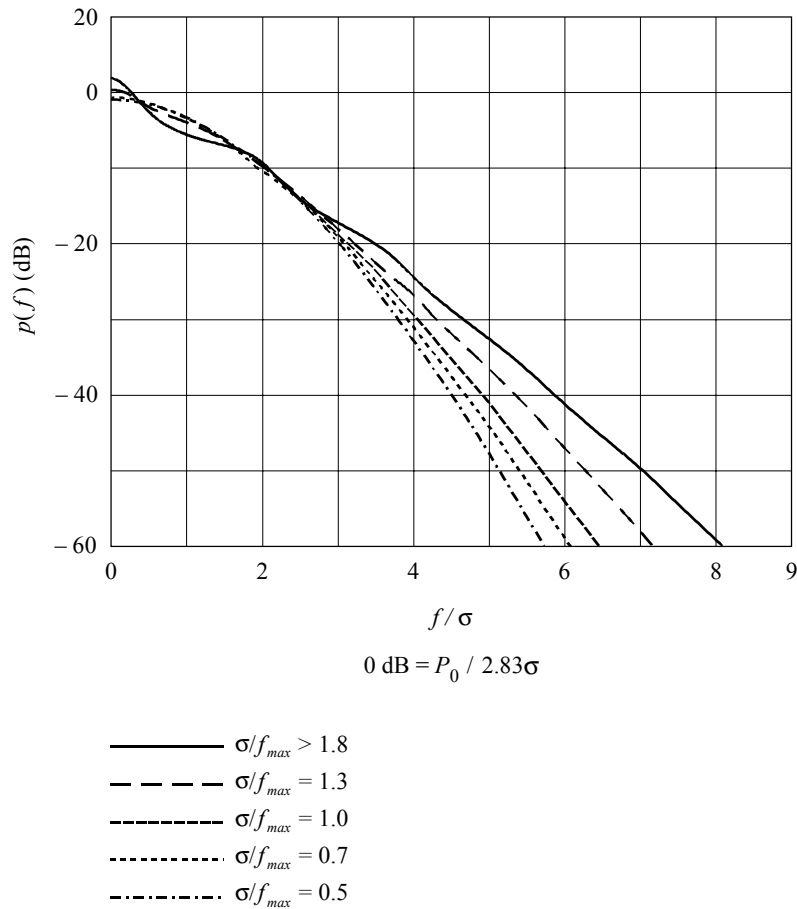

The following symbols are used in Figs. 17 to 20:

- f_{max} : maximum frequency of the band limited noise
- σ : r.m.s. frequency deviation. i.e. the r.m.s. value of the difference between the instantaneous frequency and its arithmetic mean
- f : frequency separation from the centre of the spectrum
- P_0 : total power of the emission
- P' : power outside the frequencies $-f$ and $+f$ in the spectrum, i.e. the out-of-band power
- β : out-of-band power ratio P'/P_0
- $p(f)$: power density of the spectrum at frequency f

FIGURE 18
Power spectral distribution for $\sigma/f_{max} < 0.5$

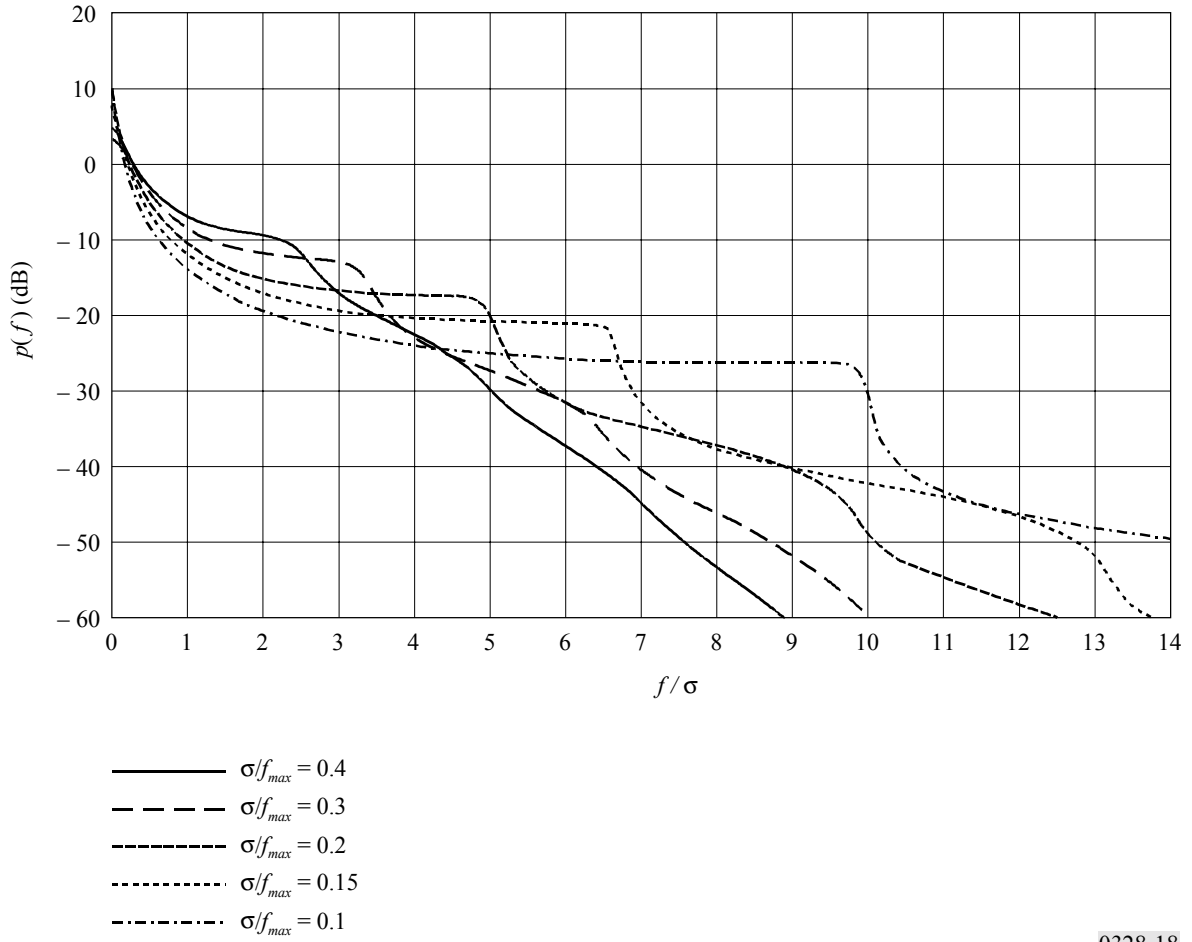

0328-18

When f is very large, the spectra decay very rapidly. It should be noted, however, that these slopes do not continue without limit. Because of the noise generated internally within the transmitter, the spectrum has a lower bound, or floor, the level of which depends upon the type of radio-frequency output stage.

3.3 Out-of-band power

Curves giving the out-of-band power of emissions with median values of frequency deviation are shown in Fig. 19. These curves have been derived from the theoretical calculation of the power spectrum.

FIGURE 19
Out-of-band power of the spectra for $\sigma/f_{max} \geq 0.5$

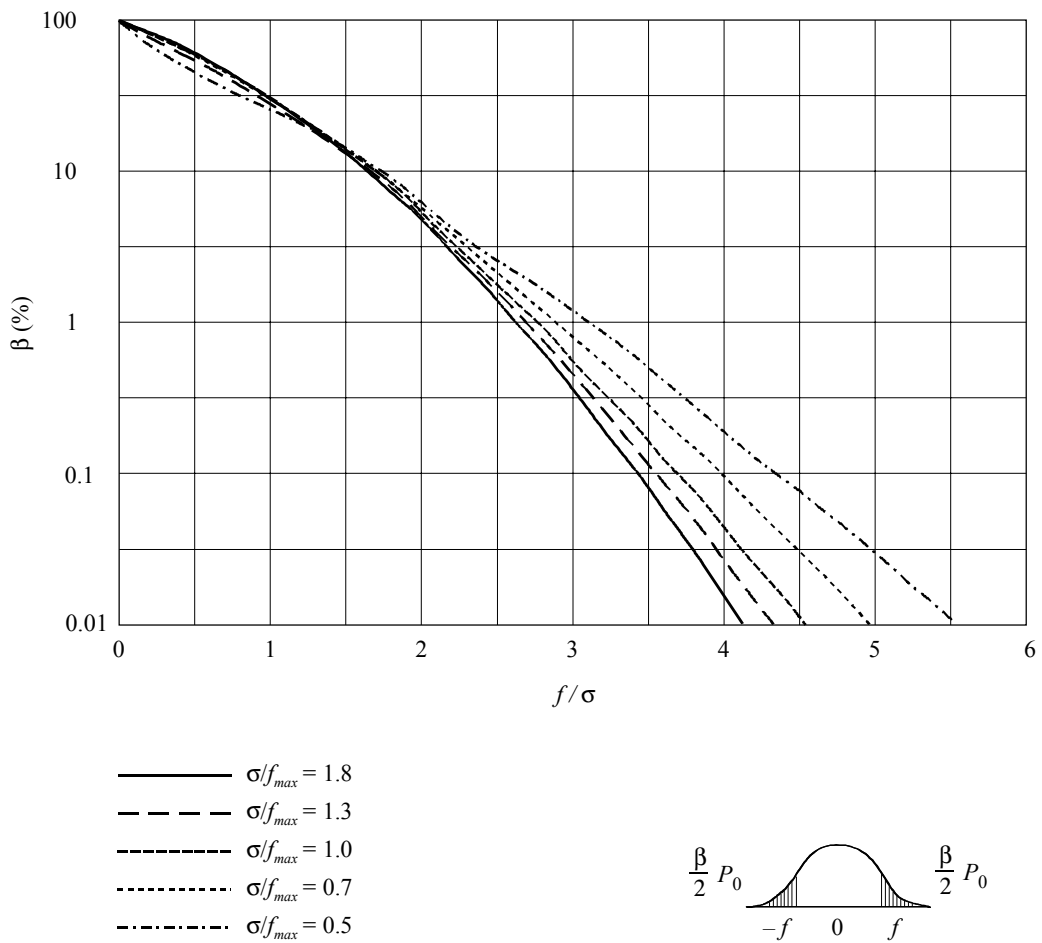

Curves relating to emissions with a small frequency deviation are given in Fig. 20. This figure has also been derived from the theoretical calculation of the power spectrum.

FIGURE 20
Out-of-band power of the spectra for $\sigma/f_{max} < 0.5$

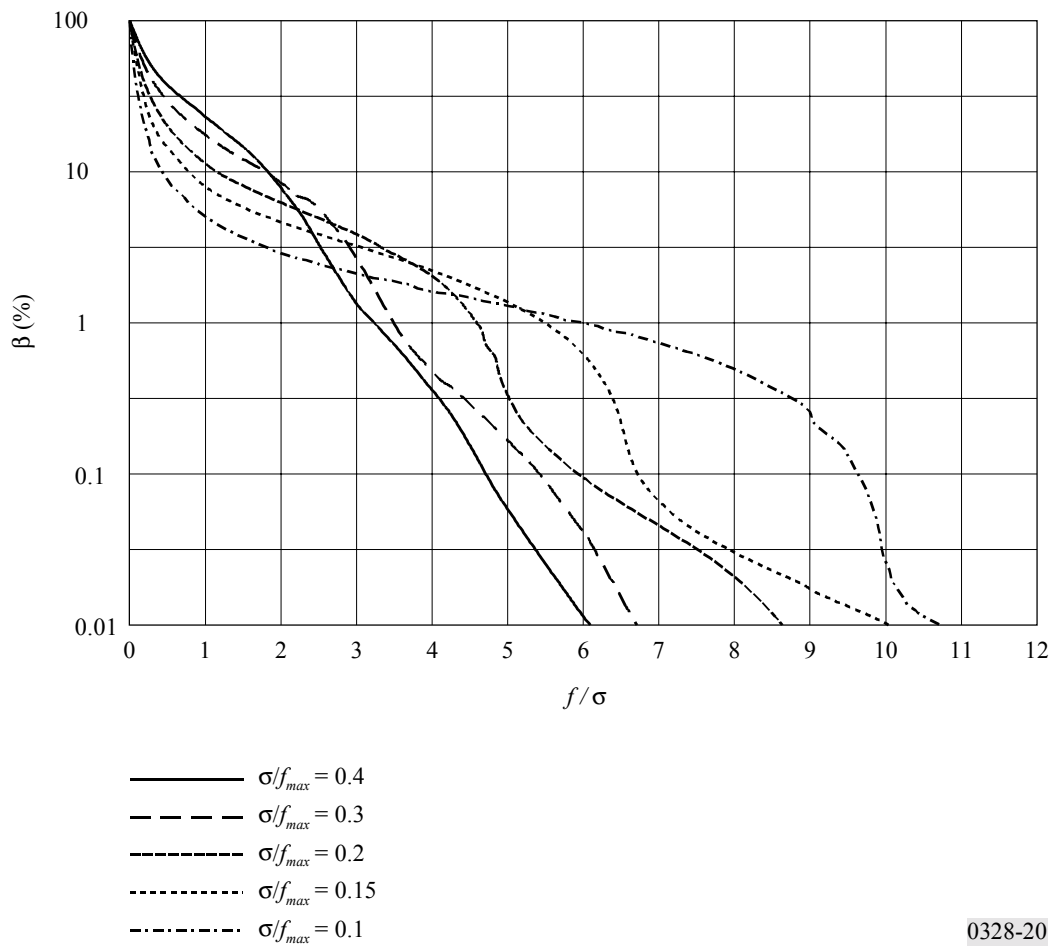

ANNEX 4

Considerations for emissions designated Type G
(Phase modulation)

TABLE OF CONTENTS

	<i>Page</i>
1 Class of emission G1B (single channel phase modulation telegraphy)	37
1.1 Necessary bandwidth	37
1.2 Out-of-band spectrum	37

1 Class of emission G1B (single channel phase modulation telegraphy)

1.1 Necessary bandwidth

The necessary bandwidth can be calculated by the following formula:

$$B_n = K B$$

where:

B : modulation rate (Bd)

$K = 5$, for radio links with fading

$K = 3$, for radio links without fading.

1.2 Out-of-band spectrum

The curve representing the out-of-band spectrum should lie below the points with the coordinates given in Table 7.

TABLE 7

Formula for calculating B_x at levels X (dB)				
-20	-30	-40	-50	-60
$3 B$	$7 B$	$13 B$	$23 B$	$41 B$

For each point of the limiting spectrum curve, the abscissa is the relative frequency $\pm B_x/2 B$, and the ordinate is the relative level X . The reference level 0 dB is the level of the unmodulated carrier.

Considerations for emissions designated Type J

(Single sideband, suppressed carrier)

TABLE OF CONTENTS

	<i>Page</i>
1 Single-sideband and independent-sideband amplitude-modulated emissions for telephony and multi-channel voice-frequency telegraphy	38
1.1 Introduction	38
1.2 Shape of the spectrum envelope for class J3E and class J7B emissions modulated with white noise	38
1.2.1 The tests described in item 1 of Table 8	41
1.2.2 The tests described in item 2 of Table 8	42
1.2.3 The tests described in item 3 of Table 8	42
1.2.4 The tests described in item 4 of Table 8	43
1.2.5 The tests described in item 5 of Table 8	43
2 Class of emission J3E, single-sideband sound broadcasting	43

1 Single-sideband and independent-sideband amplitude-modulated emissions for telephony and multi-channel voice-frequency telegraphy

1.1 Introduction

The occupied bandwidth and out-of-band radiation of amplitude-modulated emissions carrying analogue signals depend, to a varying degree, on several factors such as:

- type of modulating signal;
- the input signal level determines the modulation loading of the transmitter;
- the passband which results from the filters used in the audio-frequency stages and in the intermediate and final modulating stages of the transmitter;
- the magnitude of the harmonic distortion and intermodulation components at the frequencies of the out-of-band spectrum;
- the phase noise performance of the various oscillators within the transmitter.

The results of measurements are also dependent upon the passband of the selective measuring device employed and on its dynamic characteristics, such as the integration time of the meter, or any other devices used in conjunction with the selective measuring device.

Figure 21 shows the bandwidth, in terms of D_p , for specific percentages of the out-of-power for three different cases where:

- f : bandwidth
- D_p : peak frequency deviation
- f_{max} : highest baseband frequency
- β : percentage of out-of-band power.

1.2 Shape of the spectrum envelope for class J3E and class J7B emissions modulated with white noise

This section deals with the results of measurements made by several administrations on different designs of transmitters for classes of emission J3E and J7B.

The major characteristics of the transmitters and the test conditions relating to the measurements are summarized in Table 8.

FIGURE 21

Bandwidth, in terms of D_p , for specific percentages of the out-of-band power

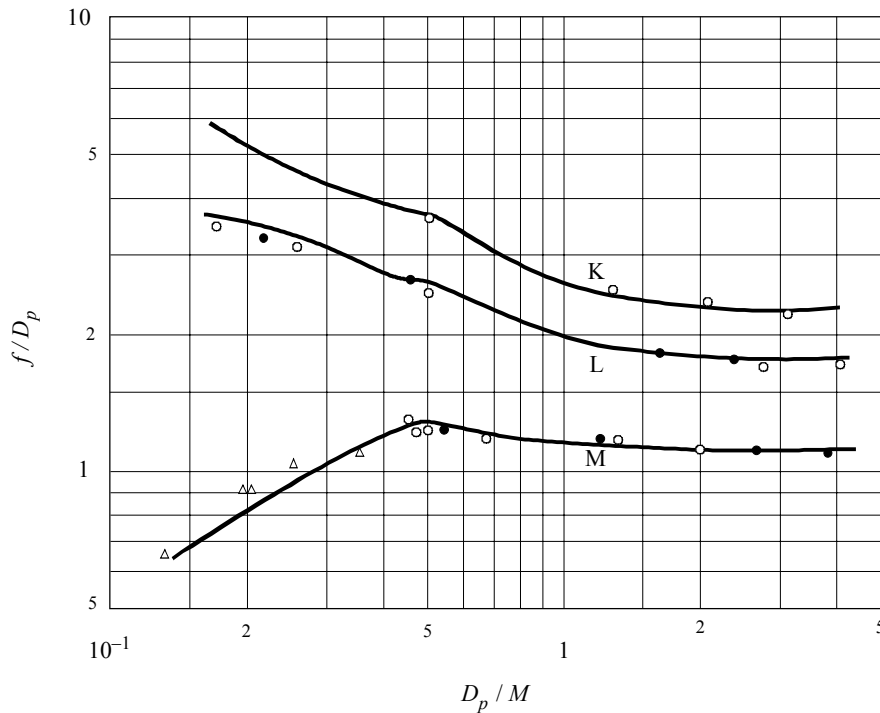

Curves K: $\beta = 0.1\%$
 L: $\beta = 1\%$
 M: $\beta = 10\%$

● ○ △ measured values

0328-21

TABLE 8

Transmitter characteristics and measurement test conditions
 for J3E and J7B emissions

Item No.	1	2	3	4	5
Class of emission	J3E	J3E	J3E	J3E; J7B	J3E
<i>Transmitter characteristics:</i>			Various transmitters		Various transmitters
– peak envelope power P_p (two tones) ⁽¹⁾ (kW)	Different values	0.150	2.5-30		Several kW to some tens of kW
– third order intermodulation distortion α_3 ⁽¹⁾ (dB)	Different values	About -40	Different values		
<i>Type of modulating signal:</i>	White noise	White noise	White noise	White noise Weighted noise	White noise
– bandwidth	Slightly smaller than B_p ⁽²⁾	Limited only by B_p ⁽²⁾	Limited only by B_p ⁽²⁾		

TABLE 8 (end)

Item No.	1	2	3	4	5
Class of emission	J3E	J3E	J3E	J3E; J7B	J3E
Input signal level ⁽¹⁾ adjusted to a value such that: – at the input, P_m (noise) = – at the output, P_m (noise) = – at the output, P_p (noise) =	P_m (two tones)	P_p (two tones)	P_m (two tones)	$0.25 P_p$ (two noise)	
Type of measuring device: – passband (Hz)		Spectrum analyser 300	Spectrum analyser		Spectrum analyser $\leq 0.05 F^{(2)}$
Shape of spectrum	See Fig. 23				See § 1.2.5

⁽¹⁾ In all tests, the transmitter is first modulated with two sinusoidal signals of equal amplitude (see Fig. 22). Next, the peak envelope power, P_p (two tones), and the third order intermodulation level, α_3 , are determined in accordance with the methods given in Recommendation ITU-R SM.326. Finally, the two sinusoidal signals are replaced by a noise signal, the level of which is adjusted to obtain one of the conditions mentioned under “input signal level”, where P_m denotes mean power and P_p denotes peak envelope power.

⁽²⁾ B_p is the passband resulting from the filters in the transmitter, and F is the necessary bandwidth.

FIGURE 22
Spectrum envelope of class J3E emission modulated with two sinusoidal signals

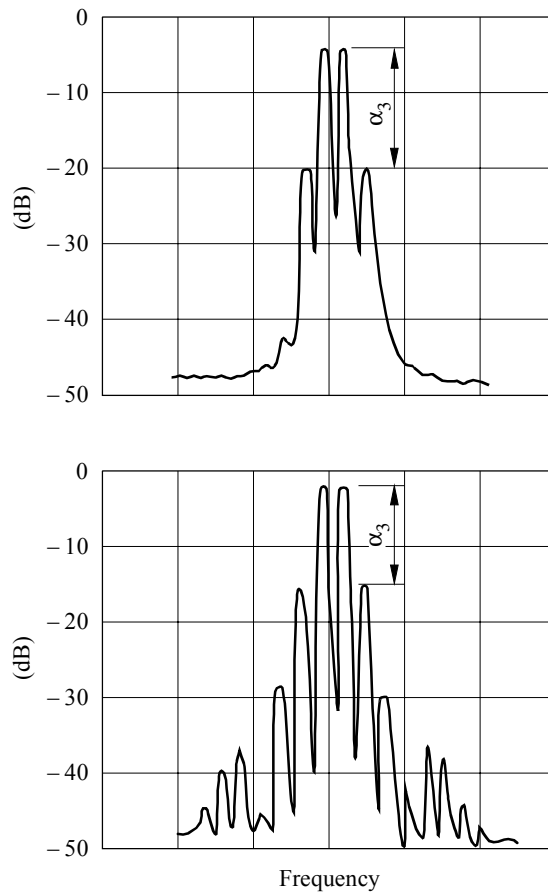

α_3 : third order intermodulation level

The results of the measurements may be summarized as follows.

1.2.1 The tests described in item 1 of Table 8

Assuming that the transmitter is operated under the conditions mentioned in item 1 of Table 8 and also assuming that the out-of-band radiation is mainly caused by intermodulation in the radio-frequency stages following the final modulator, the following may be concluded:

- the centre part of the radio-frequency spectrum exhibits a substantially rectangular form and is superimposed on a curve showing the out-of-band radiation which extends symmetrically with respect to the centre frequency (see Fig. 23);

FIGURE 23
Spectrum envelope of class J3E emission modulated with white noise

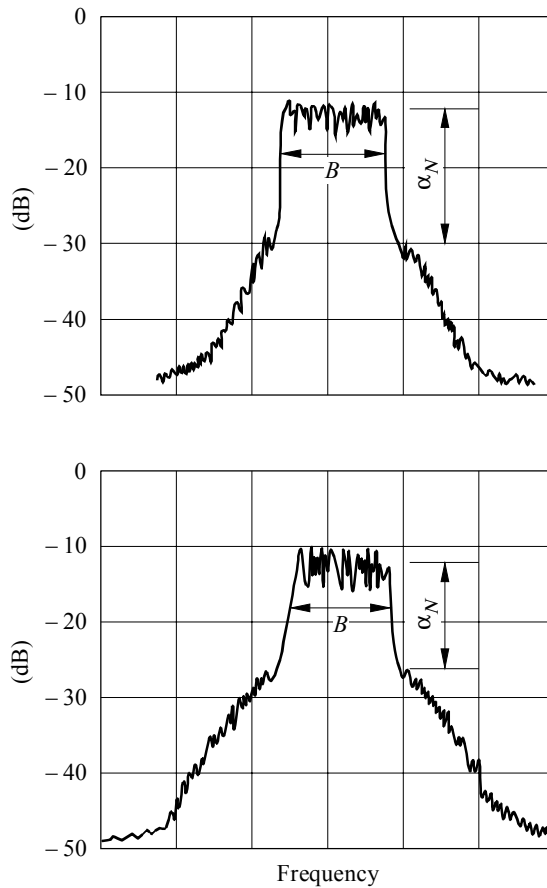

α_N : see text

B : bandwidth of noise signal

0328-23

- the difference α_N between the level of the flat portion of the top of the spectrum and the level at which the out-of-band radiation starts is generally equal to the level of the third order intermodulation component α_3 (see Fig. 24);

FIGURE 24
The value of α_N shown in Fig. 23 for different values of α_3

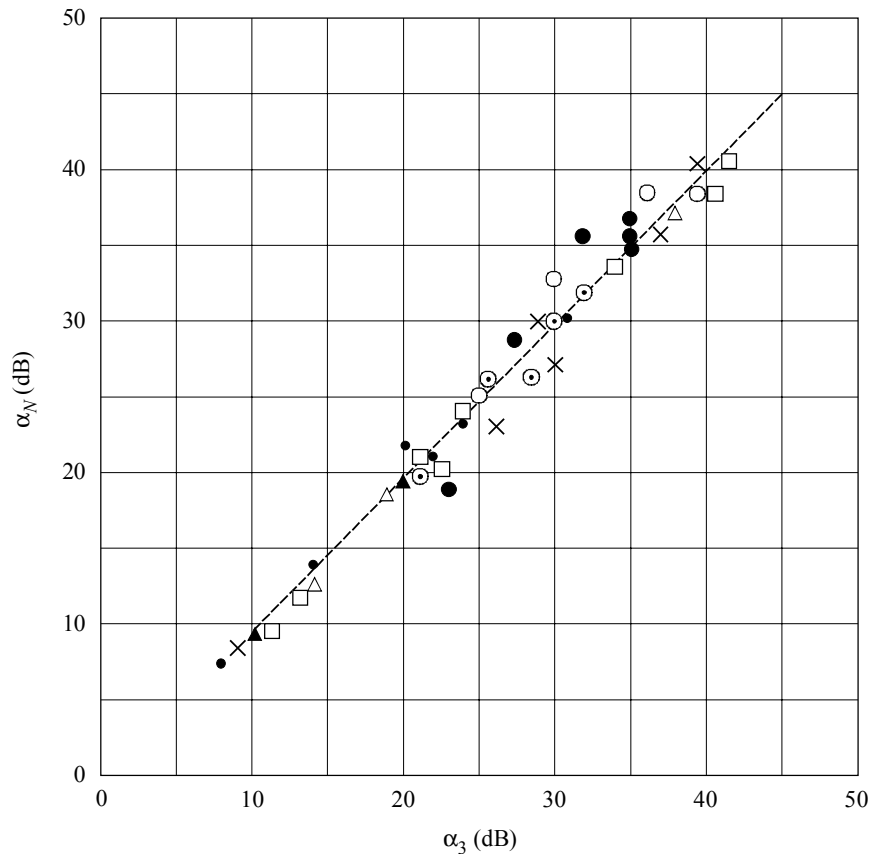

0328-24

- the slope (dB/Hz) of the curve representing the out-of-band radiation, is inversely proportional to the bandwidth B of the noise signal at the input;
- the slope is constant, at least in the neighbourhood of the limits of the bandwidth, and has a value between 10 and 20 dB per bandwidth B , dependent on the character of the distortion (see Fig. 25);
- the bandwidth occupied by the emission is equal to the width of the main spectrum, provided that α_3 is at least 20 dB.

The above conclusions are expected to be also valid in those cases where the modulating signal is similar to white noise, such as radiotelephone emissions using a band-splitting privacy device and multi-channel voice-frequency radiotelegraph emissions.

1.2.2 The tests described in item 2 of Table 8

The results, particularly with respect to the level at which the out-of-band radiation starts, correspond very closely to those obtained from the measurements described in item 1 of Table 8 and in item 1 of Table 3.

1.2.3 The tests described in item 3 of Table 8

The transmitters used in these tests, although of different design and power rating, used triodes in the final stage which were capable of being driven into grid current.

In one series of tests, the transmitters were fairly heavily loaded in order to determine the possible influence of grid current. Under this condition the third order intermodulation distortion level α_3 , was rather poor and there appeared to be a fairly large difference between the value of α_3 and the level α_N in the power spectrum at which the out-of-band radiation starts.

FIGURE 25
The value of the slope in the vicinity of the bandwidth
for different values of α_3

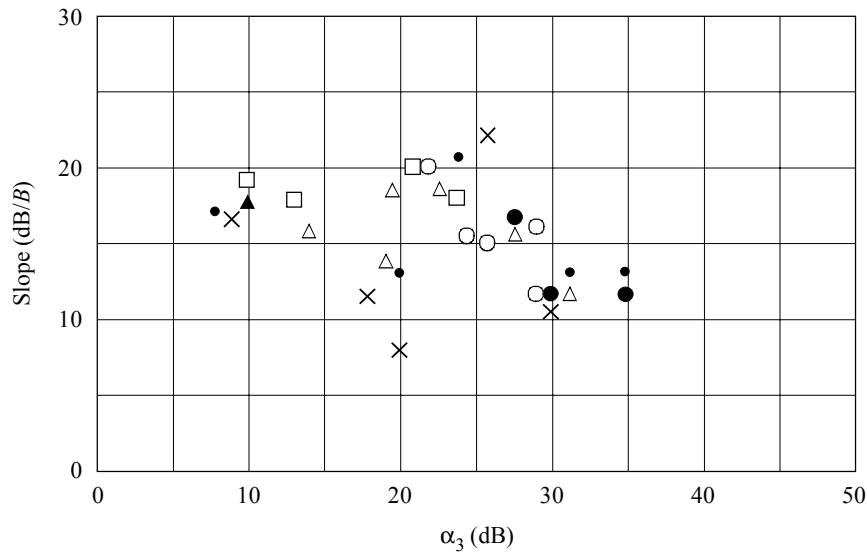

0328-25

In a second series of tests, α_N and α_3 were determined as a function of the modulation input level. For the lower values of this level the relation $\alpha_3 = \alpha_N$, was approximately satisfied.

Furthermore, it has been observed that under the modulating conditions mentioned in item 3 of Table 8, the mean power of the noise-modulated radio-frequency signal was about 1 dB greater than the mean power of the radio-frequency signal modulated with two sinusoidal signals. This causes the peak envelope power to be exceeded for a considerable percentage of the time. This condition does not correspond to the practices generally adopted in actual traffic and further experiments seem to indicate that it might be necessary to adjust the level of the noise signal to a value which is 2-3 dB lower than that used in the tests just mentioned.

1.2.4 The tests described in item 4 of Table 8

The adjustment of the input signal level mentioned in item 4 of Table 8 applies to both transmitters for class of emission J3E and transmitters for class of emission J7B. In this case the following relationship is satisfied with respect to the power of the radio-frequency signal:

$$P_m (\text{noise}) = 0.5 P_m (\text{two tones}) = 0.25 P_p (\text{two tones}) \quad (16)$$

Under this condition the envelope of the noise-modulated signal will not exceed the level corresponding to the rated peak envelope power for more than about 2% of the time.

If, with a transmitter for class of emission J3E, the noise signal is weighted, the same adjustment can be used.

1.2.5 The tests described in item 5 of Table 8

If frequency is plotted as the abscissa in logarithmic units, the reference frequency being assumed to coincide with the centre of the necessary bandwidth F , and if the power densities are plotted as ordinates (dB) the curves representing the out-of-band spectra produced by a number of transmitters of different power rating for class of emission J3E lie below two straight lines, starting at point $(+0.5 F, 0 \text{ dB})$, or at point $(-0.5 F, 0 \text{ dB})$, and finishing at point $(+0.6 F, -30 \text{ dB})$ or $(-0.6 F, -30 \text{ dB})$, respectively. Beyond the latter points and down to the level -60 dB , the curves lie below two straight lines, starting from the latter point and having a slope of 12 dB/octave.

2 Class of emission J3E, single-sideband sound broadcasting

Refer to RR Appendix S11 (Double-sideband (DSB) and single-sideband (SSB) system specifications in the HF broadcasting service), Part B (Single-sideband (SSB) system).

Digital phase modulation

TABLE OF CONTENTS

	<i>Page</i>	
1	Binary phase shift keying (BPSK) and quaternary phase shift keying (QPSK).....	45
1.1	Description of the scheme	45
1.2	Power spectra	45
1.3	Influence of the pulse shaping function	47
1.4	Practical implementation.....	50
2	Continuous phase modulation (CPM).....	50
2.1	System description	50
2.2	Spectrum	51
2.3	Occupied bandwidth.....	52
3	Gaussian minimum shift keying (GMSK).....	53
3.1	Basic formulae.....	53
3.1.1	Filtering	53
3.1.2	Output phase.....	54
3.1.3	Modulation	54
3.2	Properties and characteristics	54
3.2.1	Spectrum.....	54
3.2.2	Occupied bandwidth.....	55
3.2.3	Eye diagrams	56
3.3	Practical considerations.....	57
4	<i>M</i> -ary QAM, $\pi/4$ QPSK and $\pi/4$ DQPSK modulations	57
4.1	<i>M</i> -ary QAM modulation.....	57
4.1.1	Modulated signal	57
4.1.2	Power spectral density.....	58
4.1.3	Bandwidth	58
4.2	$\pi/4$ QPSK and $\pi/4$ DQPSK modulations.....	58
4.2.1	Modulated signal	58
4.2.2	Power spectral density.....	59
4.2.3	Bandwidth	59
5	Orthogonal frequency division multiplexing (OFDM).....	59
5.1	The basic idea.....	59
5.2	OFDM modulation scheme	60
5.3	An OFDM system	61
5.4	Useful data carriers	61
5.5	Spectrum characteristics.....	62
5.6	Influence of non-linearities	63
6	Spread spectrum	64

1 Binary phase shift keying (BPSK) and quaternary phase shift keying (QPSK)

BPSK and QPSK advantages are in the low probability of error at a given signal-to-noise ratio (S/N). They are used in systems where the received SNR is not very good, or where the coherent detection is more difficult to achieve.

The characteristics of the BPSK modulation scheme and the spectral power density are introduced with the extension to QPSK (and also to 8-PSK), the pulse shaping and its influence on out-of-band emissions.

1.1 Description of the scheme

In the binary PSK system, the symbols “1” and “0” are represented by the two signals $s_1(t)$ and $s_2(t)$:

$$s_1(t) = \sqrt{\frac{2E_b}{T_b}} \cos(2\pi f_c t) \quad (17)$$

$$s_2(t) = \sqrt{\frac{2E_b}{T_b}} \cos(2\pi f_c t + \pi) = -\sqrt{\frac{2E_b}{T_b}} \cos(2\pi f_c t) \quad \text{for } 0 \leq t \leq T_b \quad (18)$$

where:

E_b : transmitted signal energy per bit

f_c : frequency of the carrier.

The two signals are referred to as antipodal signals.

In the BPSK, one basis function of unit energy is required to describe the signal:

$$\phi_1(t) = \sqrt{\frac{2}{T_b}} \cos(2\pi f_c t) \quad \text{for } 0 \leq t \leq T_b \quad (19)$$

so this modulation is characterized by one-dimensional signal space ($N = 1$) and two message points ($M = 2$).

1.2 Power spectra

The expression for the spectral power density is derived as follows:

The signal is written in terms of its in-phase and quadrature components:

$$\begin{aligned} s(t) &= s_I(t) \cos(2\pi f_c t) - s_Q(t) \sin(2\pi f_c t) \\ &= \operatorname{Re}[\tilde{s}(t) \exp(j2\pi f_c t)] \end{aligned} \quad (20)$$

The baseband power spectral density $S_B(f)$ of the complex envelope $\tilde{s}(t)$ is used as a measure for the power spectrum of the signal $s(t)$. $S_B(f)$ is related to the power spectral density of the signal $s(t)$ via the relation:

$$S_s(f) = \frac{1}{4} [S_B(f - f_c) + S_B(f + f_c)] \quad (21)$$

In the BPSK, the inphase component equals to $\pm g(t)$ (the quadrature component equals zero):

$$g(t) = \begin{cases} \sqrt{\frac{2E_b}{T_b}} & \text{for } 0 \leq t \leq T_b \\ 0 & \text{elsewhere} \end{cases} \quad (22)$$

and its square magnitude Fourier transform divided by the symbol duration gives the baseband power density as shown in Fig. 26:

$$S_B(f) = \frac{2E_b \sin^2(\pi T_b f)}{(\pi T_b f)^2} = 2E_b \operatorname{sinc}^2(T_b f) \quad (23)$$

FIGURE 26
BPSK spectrum

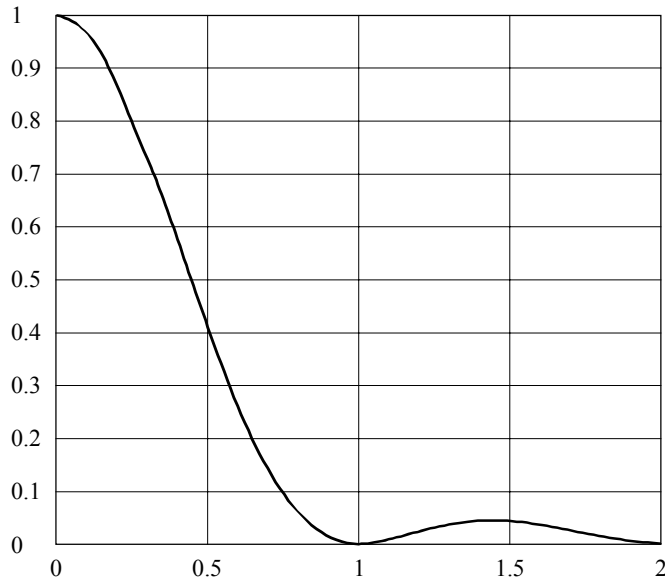

0328-26

The BPSK is a special case of the M -ary PSK signals, that have the following form:

$$s(t) = \sqrt{\frac{2E}{T}} \cos\left(2\pi f_c t + \frac{2\pi}{M}(i-1)\right) \quad \text{for } i = 1, 2, \dots, M \quad (24)$$

The average probability of symbol error for the coherent M -ary PSK is given by:

$$P_e \approx \operatorname{erfc}\left(\sqrt{\frac{E}{N_0}} \sin\left(\frac{\pi}{M}\right)\right) \quad (25)$$

where:

$$\operatorname{erfc}(x) = \int_x^{\infty} e^{-t^2} dt$$

The baseband power spectrum density reads:

$$S_B(f) = 2E \operatorname{sinc}^2(Tf) = 2E_b \log_2 M \operatorname{sinc}^2(T_b f \log_2 M) \quad (26)$$

where:

$$\operatorname{sinc}(x) = \frac{\sin(x)}{x}$$

The power spectra of M -ary signals for $M=2, 4, 8$ are given in Fig. 27. For $M=2$ we have the BPSK spectrum; for $M=4$ we have the QPSK spectrum, and for $M=8$ we have the 8-PSK spectrum.

FIGURE 27
BPSK, QPSK and 8-PSK spectrum

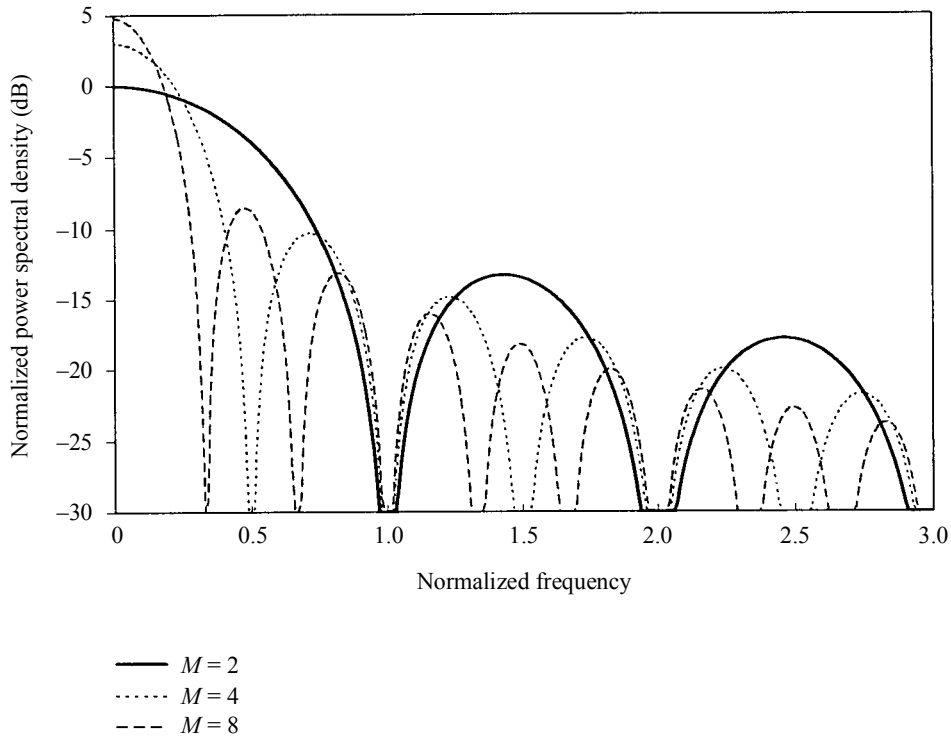

0328-27

1.3 Influence of the pulse shaping function

The modulation spectrum derived before was calculated for a pulse of the form:

$$g(t) = \begin{cases} \sqrt{\frac{2E_b}{T_b}} & \text{for } 0 \leq t \leq T_b \\ 0 & \text{elsewhere} \end{cases} \quad (27)$$

and we have seen that the resulting spectrum is infinite.

Figure 28 illustrates the practical transmission scheme on a band-limited channel.

FIGURE 28
Transmission on a band-limited channel

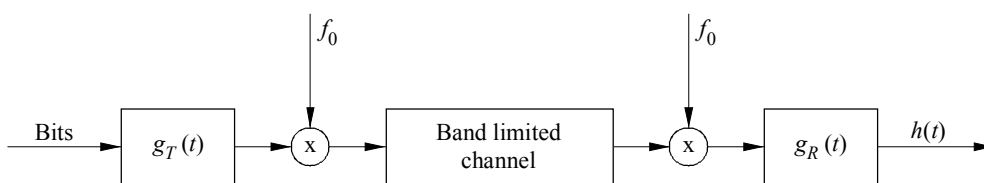

0328-28

The truncation of the higher secondary lobes of $G(f)$ by the band limited channel results in non-zero values of $h(t)$ for $t = kT$, $k \neq 0$. This effect of inter symbol interference (ISI) makes the reception more difficult.

To avoid ISI, one has to respect the following condition (Nyquist Theorem) in the design of the transmission filter:

The necessary and sufficient condition for $x(t)$ to satisfy:

$$x(nT) = \begin{cases} 1 & n = 0 \\ 0 & n \neq 0 \end{cases} \quad (28)$$

is that its Fourier transform $X(f)$ satisfy:

$$\sum_{m=-\infty}^{\infty} X(f + m/T) = T \quad (29)$$

A particular well-known pulse shape that satisfies the Nyquist criterion is the raised cosine, that has the following characteristics:

$$X_{rc}(f) = \begin{cases} T & \text{for } 0 \leq |f| \leq \frac{1-\beta}{2T} \\ T/2 \left\{ 1 + \cos \left[\frac{\pi T}{\beta} \left(|f| - \frac{1-\beta}{2T} \right) \right] \right\} & \text{for } \frac{1-\beta}{2T} \leq |f| \leq \frac{1+\beta}{2T} \\ 0 & \text{for } |f| \geq \frac{1+\beta}{2T} \end{cases} \quad (30)$$

The parameter β , that is defined as the roll-off factor, ranges between 0 and 1. It determines the bandwidth occupied by the raised cosine filter. Choosing a larger β makes the implementation of the filter easier, but increases the occupied bandwidth.

This filter is equally distributed between the transmitter and the receiver sides. The transmitting pulse shape is defined by its spectrum:

$$G_T(f) = \sqrt{X_{rc}(f)} e^{-j2\pi f t_0} \quad (31)$$

where t_0 is a delay.

In an ideal world, the spectrum of the transmitted signal would be strictly band-limited, and there would be no need to care for out-of-band emissions. In the practical implementation of the filter, the non-linearities and other effects cause secondary lobes to appear.

Only one of these effects is examined in this contribution:

The $g_T(t)$ that corresponds to the above spectrum has an infinite support in the time domain, which is not physically achievable. If we pass this pulse through a time window:

$$w(t) = \begin{cases} 1 & \text{for } |t| \leq \alpha T \\ 0 & \text{elsewhere} \end{cases} \quad (32)$$

we cause secondary lobes to appear. Figure 29 shows the effect of this window for different apertures ($\alpha = 1; 2; 4$), and different roll-offs ($\beta = 0.01; 0.5; 1$).

FIGURE 29
 Spectrum with roll-offs = 0.01, 0.5 and 1

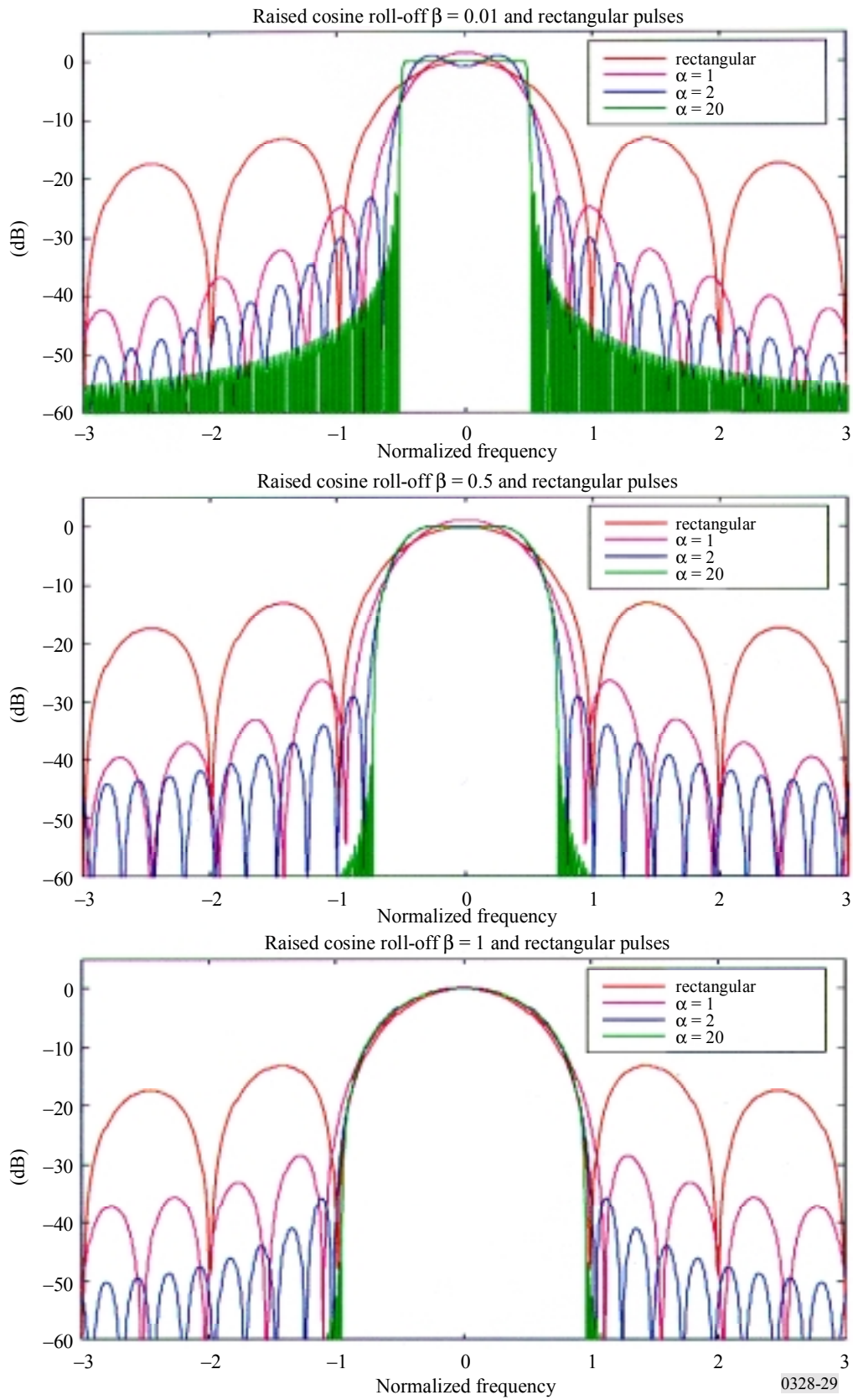

1.4 Practical implementation

BPSK and QPSK when filtered exhibit strong amplitude variations, compared with constant envelope for the unfiltered case. Any non-linearity in the high power amplifier for filtered PSK causes the sidebands to reappear. This can be reduced in practice by using offset QPSK (OQPSK) modulation in which the orthogonal components and the envelope variations are reduced.

2 Continuous phase modulation (CPM)

CPM is an attractive modulation scheme because it combines good spectral efficiency with low sensitivity to non-linearities. There is a wide range of possible implementations, including the classical minimum shift keying (MSK) and tamed frequency modulation (TFM) schemes. CPMs are constant envelope modulations.

A class of CPM signals, which is suitable for multi-states signalling, is described in the following paragraphs.

2.1 System description

The incoming binary data with bit duration T_b are grouped into N -ples of duration $T_s = NT_b$. Each N -ple is mapped onto one symbol a_k from an M -ary alphabet ($M = 2^N$). In the modulator, ISI is deliberately introduced by shaping the symbols with a frequency modulating pulse $g(t)$ which extends over L symbols (partial response modulation). The signal at the output of the pulse shaping circuit is given by:

$$b(t) = \sum_{k=-\infty}^{\infty} a_k g(t - kT_s) \quad (33)$$

After frequency modulation, the constant envelope CPM signal is given by:

$$s(t) = \sqrt{\frac{2E_b}{T_b}} \cos(2\pi f_c t + \varphi(t) + \varphi_0) \quad (34)$$

where:

E_b : energy per bit

f_c : carrier frequency

φ_0 : arbitrary constant phase

$\varphi(t)$: information carrying phase:

$$\varphi(t) = 2\pi h \int_{-\infty}^t b(\tau) d\tau = 2\pi h \sum_{k=-\infty}^{\infty} a_k q(t - kNT_b) \quad (35)$$

Here h is the modulation index and $q(t)$ is the normalized phase shaping pulse, related to $g(t)$ and such that:

$$\begin{aligned} q(t) &= 0 & \text{for } t &\leq 0 \\ q(t) &= 1/2 & \text{for } t &\geq LT_s \end{aligned} \quad (36)$$

While for $0 < t \leq LT_s$, in practical implementations, $q(t)$ may be described in a simplified form by a polynomial:

$$q(t) = \frac{1}{4} + m \left(\frac{t}{T_s} - \frac{L}{2} \right) + \frac{5-8mL}{L^3} \left(\frac{t}{T_s} - \frac{L}{2} \right)^3 + \frac{16mL-12}{L^5} \left(\frac{t}{T_s} - \frac{L}{2} \right)^5 \quad \text{for } 0 < t \leq LT_s \quad (37)$$

Where m , L (the shaping pulse duration in symbols) are design parameters.

For a 2-state ($M = 2$) modulation $h = 0.5$ is best suited. Moreover using $h = 0.5$ with $m = 0.25$ and $L = 4$ also a very good approximation of the classical TFM modulation is obtained.

2.2 Spectrum

Figure 30 shows the simulated power density spectra for two cases of 2-state modulation with $h = 0.5$ and ($L = 3$, $m = 0.32$) and ($L = 4$, $m = 0.25$) respectively. The amplitudes are in dB, normalized to the mid-band value, the frequencies are normalized to the bit rate f_b .

FIGURE 30
 Simulated power density spectra for two cases of 2-state CPM ($h = 0.5$)

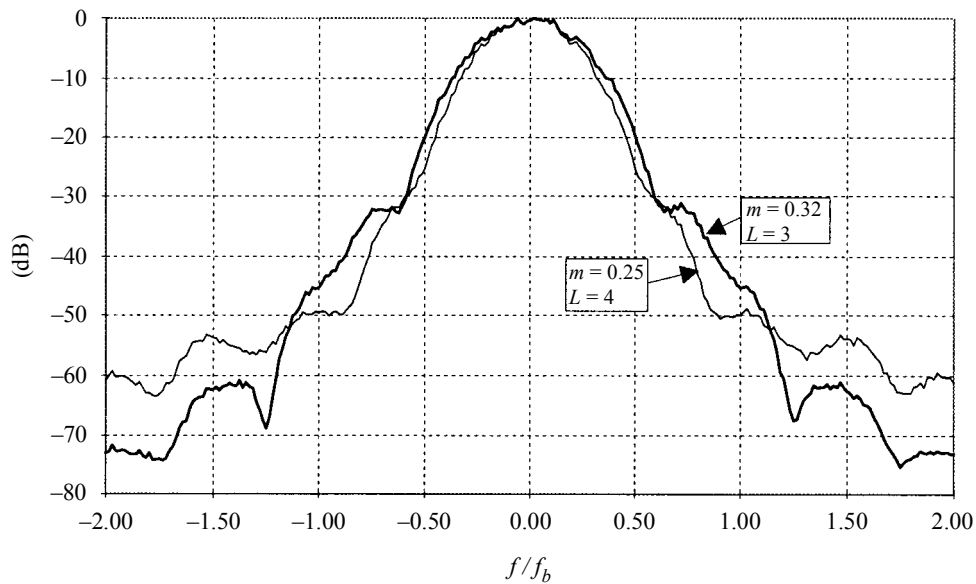

0328-30

Figure 31 shows the simulated power density spectra for a 4-state ($M = 4$) modulation with $m = 0.49$, $L = 2$ (equivalent to a 2RC: raised cosine frequency pulse spanning over two-symbol intervals) and various modulation indexes. The amplitudes are in dB, normalized to the mid-band power density, frequencies are normalized to the bit rate f_b .

FIGURE 31
 Simulated power density spectra for a 4-state CPM (2RC pulse)

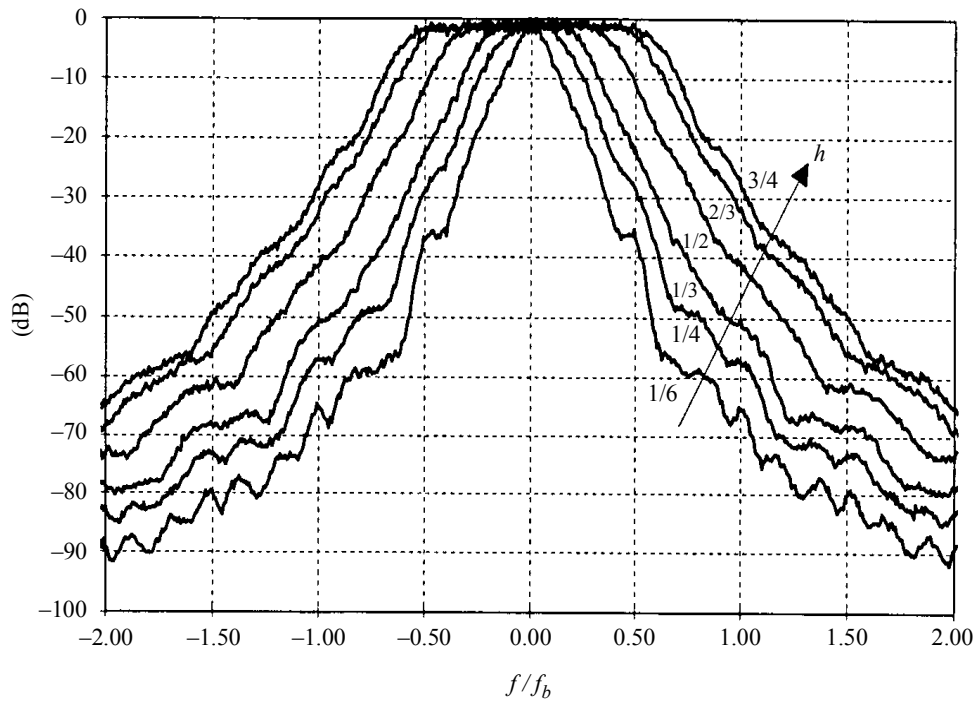

0328-31

Spectrum is dependent on baseband filter in the practical implementation.

2.3 Occupied bandwidth

Tables 9 and 10 give the occupied bandwidth at 95% and 99% of the total two-sided RF spectrum for the cases shown in Fig. 30 and Fig. 31 respectively. The values are normalized to the bit rate.

TABLE 9
 2-state CPM, $h = 0.5$

B/f_b	$L = 3, m = 0.32$	$L = 4, m = 0.25$
99%	0.87	0.80
95%	0.69	0.62

TABLE 10
 4-state CPM, 2RC pulse

B/f_b	$h = 1/6$	$h = 1/4$	$h = 1/3$	$h = 1/2$	$h = 2/3$	$h = 3/4$
99%	0.51	0.63	0.79	1.05	1.32	1.44
95%	0.35	0.48	0.59	0.86	1.11	1.24

3 Gaussian minimum shift keying (GMSK)

GMSK is an extension and an improvement of the very classical digital modulation scheme MSK.

MSK, named also fast frequency shift keying (FFSK), is a special case of continuous phase frequency shift keying (CPFSK) with deviation ratio equal to 0.5.

But MSK is also equivalent to a form of OQPSK in which the symbol pulse shape is a half cycle sinusoid rather than the basic non-filtered rectangular pulse.

The envelope of an MSK modulated RF carrier is constant and suffers little degradation from transmitting non-linear devices (MSK is a frequency modulation). Thus MSK (like QPSK) can be also defined as a linear modulation scheme with antipodal symbol pulses and allows coherent detection that means optimal resistance to unwanted noise and interference.

At the end of the 1970s and the beginning of the 1980s a lot of research and development (R&D) actions were conducted to improve this basic modulation scheme with the following goals and constraints:

- efficient bandwidth utilization (narrow occupied bandwidth and suitable spectral purity properties);
- constant amplitude (easy transmitters implementation, suitable power efficiency, minimum risk of intermodulation products generation);
- low degradation of bit error rates properties (to remain as close as possible to a linear antipodal modulation scheme);
- easy implementation (modulator and demodulator processing).

In fact, the four above requirements being more or less incompatible, the main object of these investigations was to design a good compromise. GMSK is the result of one of these R&D efforts and since the beginning of the 1990s has been extensively used in the field of the land mobile services.

3.1 Basic formulae

3.1.1 Filtering

The modulating data values (d_i) as represented by Dirac pulses exit a linear filter with impulse response defined by:

$$g(\tau) = h(\tau) * \text{rect}(\tau/T) \quad (38)$$

where the function $\text{rect}(x)$ is defined by:

$$\begin{aligned} \text{rect}(\tau/T) &= 1/T & \text{for } |\tau| < T/2 \\ \text{rect}(\tau/T) &= 0 & \text{otherwise} \end{aligned} \quad (39)$$

and (*) means convolution.

$h(t)$ is defined by the Gaussian density function:

$$h(\tau) = \exp\left(-\frac{\tau^2}{2\sigma^2 T^2}\right) / (\sigma T \sqrt{2\pi}) \quad (40)$$

where:

$$\sigma = \frac{\sqrt{\ln 2}}{2\pi BT} \quad (41)$$

with:

ln: natural logarithm (base = e)

B : 3 dB bandwidth of the filter with impulse response $h(\tau)$

T : the duration of one input data symbol.

BT is the parameter defining the GMSK modulation type. $BT = \infty$ corresponds to MSK. In practice the used BT values are smaller than 1.

$$BT(\text{DECT}) = 0.50$$

$$BT(\text{GSM/DCS/PCS}) = 0.30$$

$$BT(\text{Tetrapol}) = 0.25$$

3.1.2 Output phase

The phase of the modulated carrier is:

$$\varphi(t) = \sum_i \left(d_i \frac{\pi}{2} \int_{-\infty}^{t-iT} g(\tau) d\tau \right) \quad (42)$$

where d_i (information bits) = ± 1 .

3.1.3 Modulation

The modulated RF carrier can be expressed as:

$$x(\tau) = \sqrt{2P} \cos(2\pi f\tau + \varphi(\tau) + \varphi_0) \quad (43)$$

where:

P : power of the carrier

f : centre frequency

$\varphi(\tau)$: modulated phase

φ_0 : constant random phase.

3.2 Properties and characteristics

From the above definition, GMSK is a constant envelope modulation scheme. Hereafter, are summarized some GMSK characteristics as a function of BT values.

$BT = 0.5, 0.3, 0.25$ and 0.15 have been considered.

3.2.1 Spectrum

Figure 32 represents the calculated power density spectrum (dB) as a function of (fT) the normalized frequency separation from the carrier centre frequency.

On each plot for comparison purposes the MSK spectrum is also represented.

The calculations were made using 10 000 random modulating data values.

FIGURE 32
GMSK spectra for $BT = 0.5, 0.3, 0.25$ and 0.15

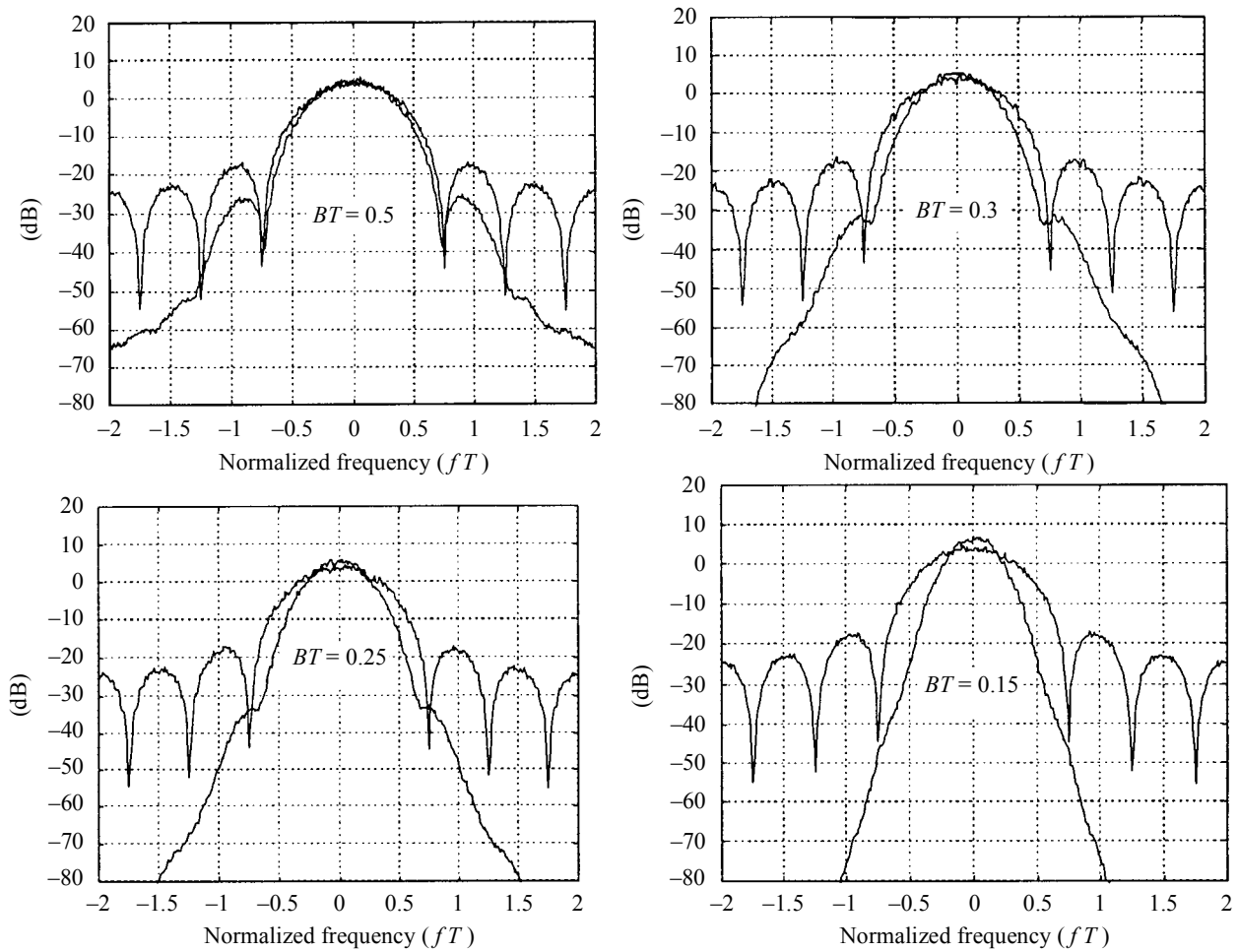

0328-32

3.2.2 Occupied bandwidth

Table 11 hereafter gives the occupied bandwidth for $(1 - \beta)\%$ of the total modulated RF signal, the units being also fT (normalized frequency). The values were issued from the above spectrum calculations.

TABLE 11
Occupied bandwidth

B	MSK	BT			
		0.50	0.30	0.25	0.15
90%	0.80	0.69	0.61	0.56	0.45
95%	0.94	0.80	0.70	0.67	0.53
99%	1.28	1.03	0.91	0.86	0.70
99.8%	2.81	1.20	1.06	1.00	0.83

3.2.3 Eye diagrams

Figure 33 represents the calculated eye diagrams at the output of a coherent detector before baseband demodulator filtering for MSK and GMSK with $BT = 0.5, 0.3, 0.25$ and 0.15 .

FIGURE 33
Eye diagrams

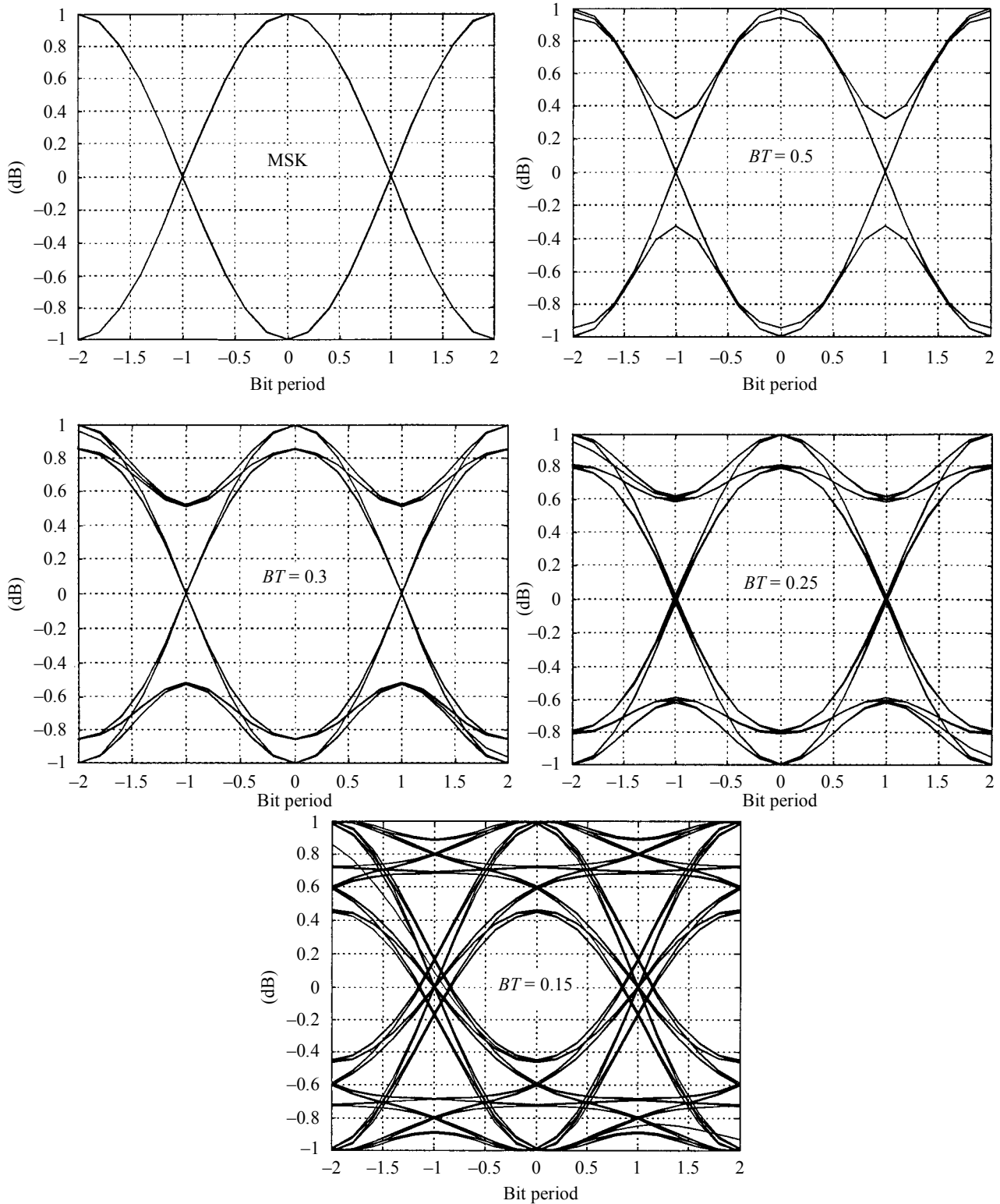

0328-33

The horizontal time axis are graduated in normalized time τ/T values (number of bit periods) and the vertical one represent the amplitude (linear scale) at the output of the coherent detector.

3.3 Practical considerations

In practice, the actual transmitted spectrum is different, generally larger, than the theoretical or calculated one as above. This is due to some defects in the modulator and/or in the transmitter of the equipment.

A part of these defects is due to the design of some components or functions, for example the design of the pre-modulation gaussian filter = length sampling rate, quantification of the filter time domain response.

Another part is due to imperfect manufacturing, for example unbalance and offset in the in-phase, I , and quadrature pulses, Q , modulator or spectral purity of the up-converter local oscillator/ synthesiser.

To individually analyse and specify the effects of every phenomenon would be very tedious.

Generally each system or standard globally specifies the overall effect of these imperfections as a limit mask for the transmitted spectrum and/or as a specification relative to the modulation accuracy measured at the transmitter output (antenna port).

4 M -ary QAM, $\pi/4$ QPSK and $\pi/4$ DQPSK modulations

4.1 M -ary QAM modulation

4.1.1 Modulated signal

The general form of an M -ary QAM signal can be defined as:

$$S_i(t) = \sqrt{\frac{2E_{min}}{T_s}} a_i \cos(2\pi f_c t) + \sqrt{\frac{2E_{min}}{T_s}} b_i \sin(2\pi f_c t) \quad \text{for} \quad 0 \leq t \leq T_s, i = 1, K, M \quad (44)$$

where:

E_{min} : energy of the signal with the lowest amplitude

T_s : symbol period

f_c : carrier frequency

a_i and b_i : pair of independent integers chosen according to the location of a particular signal point.

If rectangular pulse shapes are assumed, the signal $S_i(t)$ may be expanded in terms of a pair of basis functions defined as:

$$\begin{aligned} \phi_1(t) &= \sqrt{\frac{2}{T_s}} \cos(2\pi f_c t) & \text{for} & \quad 0 \leq t \leq T_s \\ \phi_2(t) &= \sqrt{\frac{2}{T_s}} \sin(2\pi f_c t) & \text{for} & \quad 0 \leq t \leq T_s \end{aligned} \quad (45)$$

The coordinates of the i -th message point are $a_i \sqrt{E_{min}}$ and $b_i \sqrt{E_{min}}$ where (a_i, b_i) is an element of the L by L matrix given by:

$$\{a_i, b_i\} = \begin{pmatrix} (-L+1, L-1) & (-L+3, L-1) & \dots & (L-1, L-1) \\ (-L+1, L-3) & (-L+3, L-3) & \dots & (L-1, L-3) \\ \vdots & \vdots & \vdots & \vdots \\ (-L+1, -L+1) & (-L+3, -L+1) & \dots & (L-1, -L+1) \end{pmatrix} \quad (46)$$

where $L = \sqrt{M}$.

4.1.2 Power spectral density

The symbol duration T_s of an M -ary QAM signal is related to the bit duration T_b by:

$$T_s = T_b \log_2 M$$

The power spectral density of an M -ary QAM signal with rectangular pulses is then given by:

$$\begin{aligned} P_{M-QAM} &= \frac{E_s}{2} \left[\left(\frac{\sin[\pi(f - f_c)T_s]}{\pi(f - f_c)T_s} \right)^2 + \left(\frac{\sin[\pi(f + f_c)T_s]}{\pi(f + f_c)T_s} \right)^2 \right] \\ &= \frac{E_b \log_2 M}{2} \left[\left(\frac{\sin[\pi(f - f_c)T_b \log_2 M]}{\pi(f - f_c)T_b \log_2 M} \right)^2 + \left(\frac{\sin[\pi(f + f_c)T_b \log_2 M]}{\pi(f + f_c)T_b \log_2 M} \right)^2 \right] \end{aligned} \quad (47)$$

where E_b is the energy per bit and E_s represents the energy per symbol.

4.1.3 Bandwidth

The null-to-null RF bandwidth is equal to $\frac{2}{\log_2 M} R_b$.

4.2 $\pi/4$ QPSK and $\pi/4$ DQPSK modulations

4.2.1 Modulated signal

In a $\pi/4$ QPSK transmitter, the input bit stream is partitioned by a serial-to-parallel converter into two parallel data streams $m_{I,k}$ and $m_{Q,k}$, each with a symbol rate equal to half of the incoming bit rate. The k -th in-phase (I_k) and quadrature pulses (Q_k) are produced at the output of the signal mapping circuit over time. They represent rectangular pulses over one symbol duration having amplitudes given by:

$$\begin{aligned} I_k &= I_{k-1} \cos \varphi_k - Q_{k-1} \sin \varphi_k \\ Q_k &= I_{k-1} \sin \varphi_k + Q_{k-1} \cos \varphi_k \end{aligned} \quad (48)$$

where the phase shift φ_k is related to the input symbols $m_{I,k}$ and $m_{Q,k}$ according to Table 12.

TABLE 12

Information bits $m_{I,k}, m_{Q,k}$	Phase shift φ_k
11	$\pi/4$
01	$3\pi/4$
00	$-3\pi/4$
10	$-\pi/4$

The general form of a $\pi/4$ QPSK signal is then given by:

$$S_{\pi/4 QPSK} = I(t) \cos(2\pi f_c t) - Q(t) \sin(2\pi f_c t) \quad (49)$$

where:

$$\begin{aligned} I(t) &= \sum_k I_k p(t - kT_s - T_s/2) \\ Q(t) &= \sum_k Q_k p(t - kT_s - T_s/2) \end{aligned} \quad (50)$$

The function $p(t)$ corresponds to the pulse shape, and T_s is the symbol period.

In $\pi/4$ DQPSK, the input binary sequence is first differentially encoded and then modulated using the $\pi/4$ QPSK modulator described above.

4.2.2 Power spectral density

The symbol duration T_s of a $\pi/4$ QPSK signal is related to the bit duration T_b by:

$$T_s = 2T_b$$

The power spectral density of a $\pi/4$ QPSK (and of a $\pi/4$ DQPSK) signal with rectangular pulses is then given by:

$$\begin{aligned} P_{\pi/4 QPSK} &= \frac{E_s}{2} \left[\left(\frac{\sin[\pi(f - f_c)T_s]}{\pi(f - f_c)T_s} \right)^2 + \left(\frac{\sin[\pi(f + f_c)T_s]}{\pi(f + f_c)T_s} \right)^2 \right] \\ &= E_b \left[\left(\frac{\sin[2\pi(f - f_c)T_b]}{2\pi(f - f_c)T_b} \right)^2 + \left(\frac{\sin[2\pi(f + f_c)T_b]}{2\pi(f + f_c)T_b} \right)^2 \right] \end{aligned} \quad (51)$$

where E_b is the energy per bit and E_s represents the energy per symbol.

4.2.3 Bandwidth

The null-to-null RF bandwidth is equal to the bit rate R_b .

5 Orthogonal frequency division multiplexing (OFDM)

5.1 The basic idea

In the field of digital communications, two approaches are possible to efficiently use the available channel bandwidth in order to transmit the information reliably within the transmitter power and receiver complexity constraints. The first approach consists in using a single carrier system in which the information sequence is transmitted serially. In such an approach, the time dispersion is generally much greater than the symbol duration and, hence, inter-symbol interference results from the non-ideal frequency response characteristics of the channel. Thus, an equaliser is necessary to compensate for the channel distortion.

The other approach in presence of channel distortion is to subdivide the available channel bandwidth into a number of sub-channels, such that each sub-channel is nearly ideal. This is done in parallel or multiplexed data systems. In these systems, several sequential streams of data are transmitted simultaneously, so that at any instant many data elements are being transmitted. In such a system, the spectrum of an individual data element normally occupies only a small part of the available bandwidth. In a classical parallel data system, the total signal frequency band is divided into N non-overlapping frequency sub-channels. Each sub-channel is modulated with a separate symbol and then, the N sub-channels are frequency multiplexed. A more efficient use of bandwidth can be obtained with a parallel system if the spectra of the individual sub-channels are permitted to overlap, with specific orthogonality constraints imposed to facilitate separation of the sub-channels at the receiver.

5.2 OFDM modulation scheme

OFDM which is applied for digital audio broadcasting (DAB) and digital video broadcasting (DVB – terrestrial), retains this last approach to implement an efficient data communication system. The total available bandwidth B is divided in an OFDM system into K sub-bands with orthogonal sub-carriers. The first implementation of these systems used arrays of sinusoidal generators and coherent demodulators. But for a large number of channels these arrays become unreasonably expensive and complex. However, it has been shown that a multi-carrier data signal is effectively the Fourier transform (or in fact the inverse Fourier transform) of the original serial data train, and that the bank of coherent demodulators is effectively an inverse (direct respectively) Fourier transform generator.

The transmitter and receiver digital units of such a system are shown in Figs. 34 and 35.

FIGURE 34
OFDM transmitter

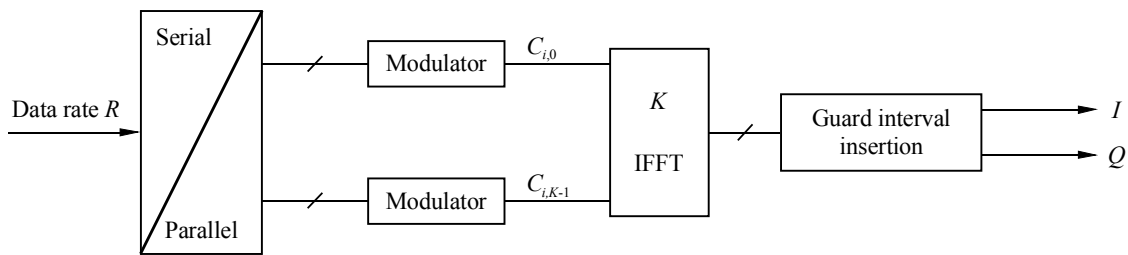

IFFT: inverse fast Fourier transform

0328-34

FIGURE 35
OFDM receiver

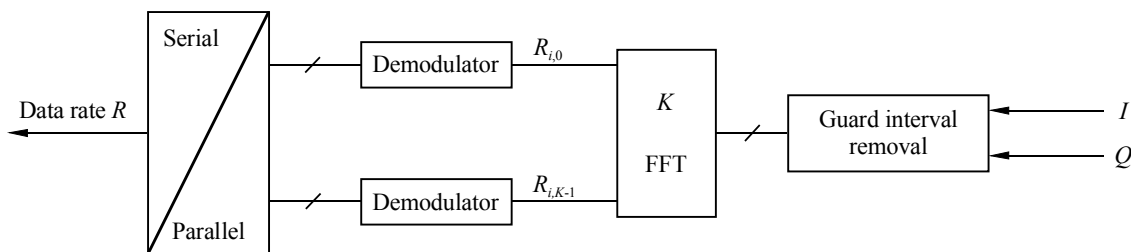

FFT: fast Fourier transform

0328-35

In this system an input sequence with a high data rate R is divided into K parallel information sequences with data rate R/K . Each sequence leads to a narrow-band signal and modulates one of K subcarriers, with frequency f_k for the k -th sub-carrier.

$$f_k = f_c + k/T_u$$

where:

$$K_{min} \leq k \leq K_{max}$$

f_c : carrier frequency.

The effective symbol interval length is described by T_u and the sub-carrier spacing is $1/T_u$. Each sequence is thus independent from the other, and can be modulated independently one from each other. After modulation, the output of each modulator is transferred to an IFFT unit from the frequency into the time domain. Inside a specific time interval of length T_u , the subcarriers overlap but are orthogonal.

In the communication channel, occurring inter-symbol interference can be eliminated in the OFDM receiver quite simply, if the effective symbol interval T_u is stretched in the receiver by a guard interval of length T_g . This guard interval is generally made of a cyclic continuation of the symbol, added before it. The resulting symbol duration is in this case $T = T_u + T_g$. If the propagation delays of the communication channel are smaller than the guard interval T_g the sub-carriers are still orthogonal, even in strong inter-symbol interference situations. This orthogonality permits a good retrieval of the data.

If the propagation delays of the channel exceed the guard interval length T_g the sub-carriers will no longer be orthogonal. So the guard interval is an important design parameter of the OFDM system.

The OFDM receiver is also quite simple. After a synchronization process, the received signal is multiplied by a rectangular window of length T_u , in order to remove the guard interval. The resulting K complex samples are then Fourier transformed using a Fast Fourier Transform (FFT) unit.

Even in strong inter-symbol interference situations, no equalizer will be used due to the narrow-band behaviour of each sub-carrier signal.

5.3 An OFDM system

The emitted signal is described by the following expression:

$$s(t) = R \left\{ e^{2\pi j f_c t} \sum_{m=0}^{+\infty} \sum_{l=0}^L \sum_{k=K_{min}}^{K_{max}} c_{m,l,k} \cdot \Psi_{m,l,k}(t) \right\} \quad (52)$$

where:

$$\Psi_{m,l,k}(t) = \begin{cases} e^{2\pi j \frac{k}{T_u} (t - T_g - lT_s - (L+1)mT_s)} & \text{for } (l + (L+1)m)T_s \leq t \leq (l + (L+1)m + 1)T_s \\ 0 & \text{otherwise} \end{cases}$$

where:

- k : sub-carrier number
- l : OFDM symbol number
- $L+1$: number of symbols per frame
- m : frame number
- T_s : symbol duration ($T_s = T_u + T_g$)
- T_u : inverse of the carrier spacing
- T_g : guard interval duration
- f_c : central frequency of the radio frequency signal
- $c_{m,l,k}$: complex symbol for carrier, k , of the data symbol, l , in frame number m
- K : number of active carriers ($= K_{max} - K_{min} + 1$).

This emitted signal reflects the organization of the data stream. The transmitted signal is organized in frames, each frame has a duration of T_f and consists of $(L+1)$ OFDM symbols.

5.4 Useful data carriers

In an OFDM system, due to the independence of each sub-carrier, the modulating signals can be independent. Data carriers in one OFDM frame can be either QPSK modulated, or QAM modulated.

Data interleaving is also introduced in order to benefit from the frequency diversity of the transmission.

5.5 Spectrum characteristics

The spectrum characteristic of this OFDM system can be derived from the emitted signal, using the definition given for the subcarriers. In order to establish the power density spectrum of the emitted signal, we restrict to the first symbol of the first frame. The sub-band carriers have frequencies:

$$f_c + k/T_u \quad (53)$$

The autocorrelation function for the k -th sub-carrier, in the baseband, is:

$$\begin{aligned} A(\tau) &= \int_{-\infty}^{+\infty} \Psi_{0,0,k}(t+\tau) \times \Psi_{0,0,k}^*(t) dt \\ &= e^{2\pi j \frac{k\tau}{T_u}} \int_{-\infty}^{+\infty} \text{rect}\left(\frac{t+\tau - \frac{T_s}{2} + T_g}{T_s}\right) \times \text{rect}\left(\frac{t - \frac{T_s}{2} + T_g}{T_s}\right) dt \\ &= e^{2\pi j \frac{k\tau}{T_u}} F(\tau) \end{aligned} \quad (54)$$

where:

$$\text{rect}(t) = \begin{cases} 1 & \text{for } -\frac{1}{2} \leq t \leq \frac{1}{2} \\ 0 & \text{otherwise} \end{cases}$$

The function $F(\tau)$ is in fact a triangle function, that is:

$$F(\tau) = \begin{cases} T_s \left(1 - \frac{|\tau|}{T_s}\right) & \text{for } -T_s \leq \tau \leq T_s \\ 0 & \text{otherwise} \end{cases} \quad (55)$$

So the power spectrum density for the k -th sub-carrier is the convolution of $\delta(f - k/T_u)$ by the Fourier transform of the triangle function:

$$P_k(f) = \left[\frac{\sin\left(\pi\left(f - f_c - \frac{k}{T_u}\right)T_s\right)}{\pi\left(f - f_c - \frac{k}{T_u}\right)T_s} \right]^2 \quad (56)$$

The overall spectrum is thus obtained by the superposition of the $(K_{max} - K_{min}) + 1$ useful carriers modulated by the corresponding data.

The transmitted spectrum tends to have rectangular shape when the number of carriers increases.

These intrinsic out-of-band emissions are reduced by appropriate IF filtering.

Production of the OFDM by digital processing can lead to spectral regrowth because of truncation. Additional regrowth can be produced in the modulator.

FIGURE 36
OFDM power spectral density

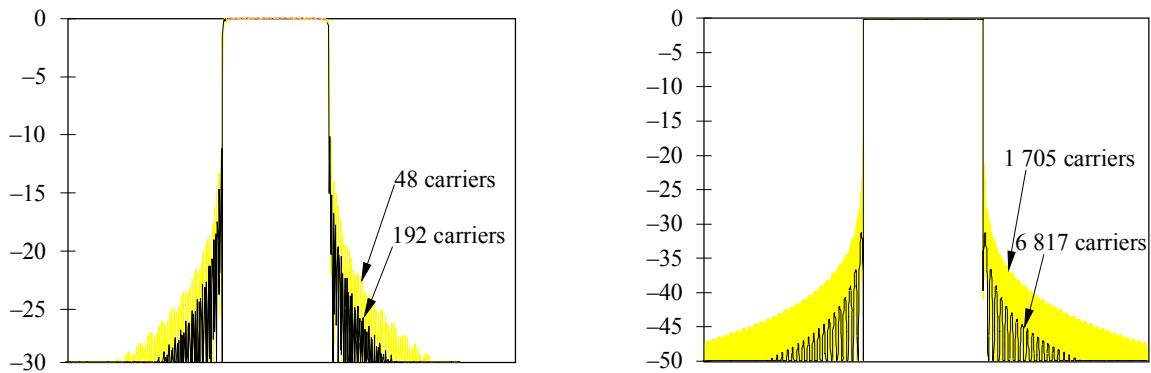

0328-36

5.6 Influence of non-linearities

The out-of-band radiation of amplified OFDM modulated signal are more critical. This results from the high dynamics of OFDM signals due to the summation of a high number of sub-carriers with random amplitude and phase. It requires a high output back-off to achieve acceptable performance in the presence of non-linear device such as the high power amplifier (HPA) of the emitters.

The theoretical non-linearity usually used to model HPAs is the memory-less envelope model. The amplifier input is expressed as an amplitude and phase modulated bandpass signal:

$$s(t) = A(t) \cos(2\pi f_c t + \varphi(t)) \quad \text{with} \quad f_c \gg B \quad (57)$$

where:

- f_c : carrier frequency
- B : bandwidth of the transmitted signal
- $A(t)$: envelope of the transmitted signal
- $\varphi(t)$: phase of the transmitted signal.

Non-linearly distorted signal harmonics at multiples of the carrier frequencies are (ideally) assumed to be rejected by the first zonal bandpass of the amplifier. The HPA output signal is expressed as:

$$s_{fz}(t) = f(A(t)) \cos[2\pi f_c t + \varphi(t) + \Phi(A(t))] \quad (58)$$

The distortions produced by a non-linear amplifier are dependant of the envelope fluctuations of the incoming signal and described by the two envelope transfer functions:

- $f(A(t))$: AM/AM conversion
- $\Phi(A(t))$: AM/PM conversion.

These distortions are about four types:

- additional non-linear interference in the receiver;
- interference between in-phase and quadrature components due to AM/PM conversion;
- spectral spreading of the signal;
- intermodulation effects.

Studies had shown that OFDM presents high robustness against in-band interference caused by non-linear amplifiers, but produces severe out-of-band interference in the adjacent channel. For DAB, a ratio of almost 30 dB (and almost 40 dB in DVB-T), also named shoulder, is required at the emitter as specification for adjacent channel interference (see Fig. 37).

FIGURE 37
Linear and non-linear simulated OFDM spectrum

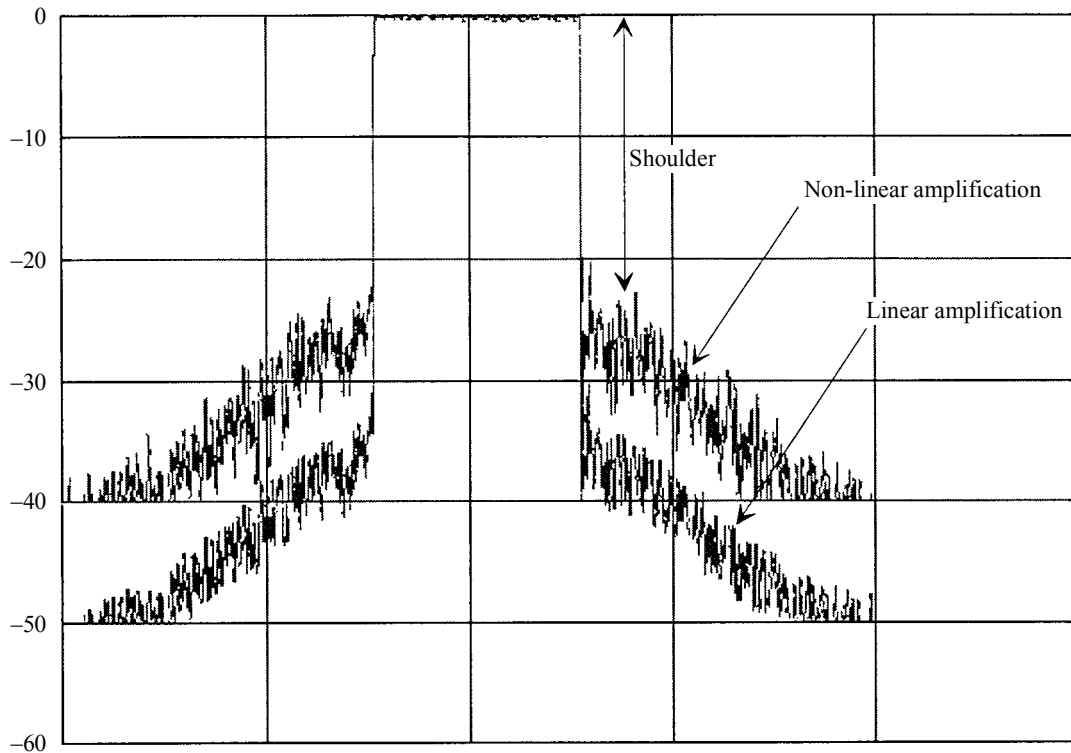

0328-37

Theory shows that, when the third order non-linearities predominate over the higher order ones, the level of these shoulders could be deduced from the level of intermodulation products generated by a two-tone signal transmitted at the same power as the OFDM signal. The shoulder level is, under such conditions, 6 dB higher than the third order intermodulation (IM3) products level.

The following methods exist to reduce these out-of-band emissions due to non-linearities:

- operating in the linear region of the high power amplifier. The necessary output back-off reduces the electrical efficiency of the amplifier. Small back-off, which is a trade-off between electrical efficiency and non-linear degradation, should be a solution;
- different devices are now available to correct non-linear effects (pre-distortion, feedback, feed-forward, ...);
- suitable coding can reduce the peak to average power ratio, thus allowing greater output for a given transmitter for a defined degree of spectral regrowth;
- post power amplifier filtering can also be used to minimize out-of-band emissions.

6 Spread spectrum

Spread spectrum techniques are those where the transmitted bandwidth of a signal is increased in order to provide one or more advantages, such as the reduction of multi-path propagation, the provision of multiple access, the reduction of spectral power density, as well as others. There are three basic forms of spread spectrum: direct sequence, frequency hopping or chirping and time dispersion. From the point of view of out-of-band emissions, direct sequence spread spectrum is the more important: the effects of frequency hopping are generally dependent on the hop rate, and are fixed either by the FM effects or the AM effects, depending on the exact implementation.

In direct sequence spread spectrum, a modulated signal is spread in the frequency domain by remodulating with a pseudo-random digital sequence, usually by a PSK modulation. Figure 38 shows a basic system.

FIGURE 38
Basic system configuration

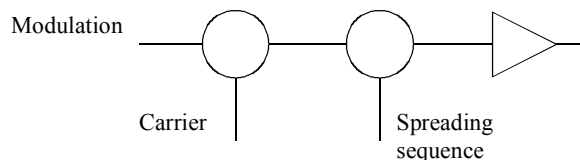

0328-38

The basic modulation is usually one that will not give a distinctive signature to the spread signal e.g. AM would still be recognizable because the spread signal would still contain the AM. Usually, a modulation system such as QPSK is used, with the resulting modulated signal being spread by the use of BPSK or QPSK for the spreading signal.

Demodulation is achieved by de-spreading the signal by using the same pseudo-random code sequence, synchronous with the received signal, and then detecting the de-spread signal. Where a number of signals are present simultaneously, the individual signal can be received by using the correct code sequence.

More detailed information concerning spread spectrum may be found in Recommendation ITU-R SM.1055.

ANNEX 7

Reduction of interference due to unwanted emissions at transmitters

TABLE OF CONTENTS

	<i>Page</i>
1 Transmitter architecture.....	66
2 Filtering.....	67
3 Modulation techniques.....	69
4 Linearization.....	71
4.1 Predistortion.....	71
4.2 Feedforward.....	72
4.3 Feedback.....	73
4.4 Modulation feedback.....	73
4.5 The Polar Loop technique.....	74
4.6 The Cartesian Loop technique.....	75
4.7 Summary.....	76

1 Transmitter architecture

The RF architecture of radio transmitters often takes the form shown in the simplified block diagram of Fig. 39. The modulated input signal is generated at an IF, then frequency translated in one or more mixing and filtering stages to the final transmitter output frequency.

FIGURE 39

Typical upconversion transmitter architecture

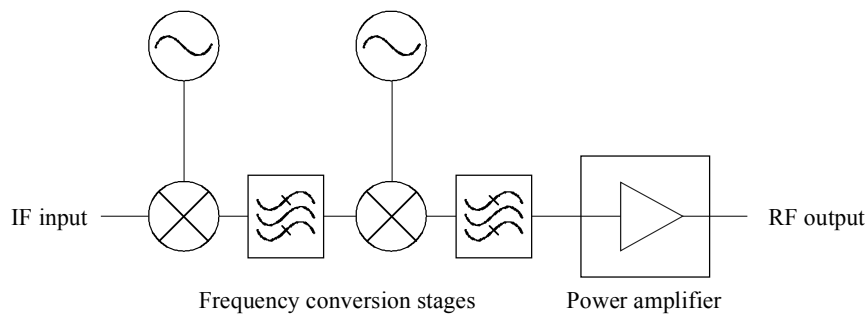

0328-39

A common problem with this arrangement is that each mixing process will produce many spurious products, as well as the main sum and difference of frequencies. These arise through mixing of the local oscillator (LO) harmonics with harmonics of the IF input. Although the LO harmonics are unavoidable due to the switching action of the mixer LO port, the IF harmonics can be reduced by ensuring that the IF level should be sufficient low within the linear portion. However, in practice, a compromise must be reached between linearity and intermodulation products which are considered as spurious emissions, so the spuri could not be completely eliminated. Spurious products which fall far from the wanted frequency can be suppressed through filtering, but those close to the carrier will not be attenuated.

One way of mitigating this problem is to generate the wanted signal directly at the final transmitter output frequency using a vector modulator, as shown in Fig. 40. In this case, in-phase (*I*) and quadrature (*Q*) baseband signals are used to directly modulate a carrier at the output frequency. Although spectral spreading of the signal into the adjacent channels can still occur, the harmonic mixing effect is eliminated, since there is only a single carrier component applied to the mixer.

FIGURE 40

Vector modulator transmitter architecture

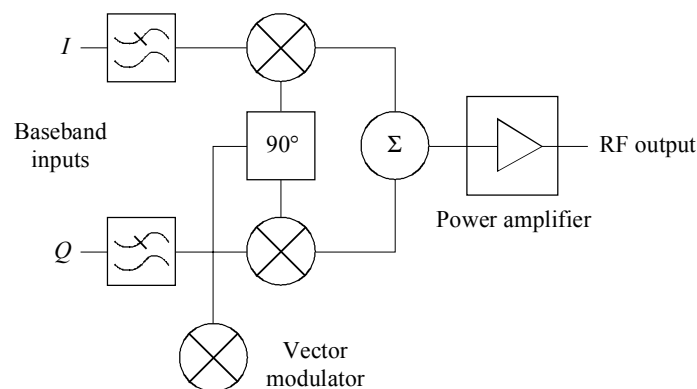

0328-40

A drawback with this arrangement is that there will be a finite carrier leakage to the output, typically suppressed by about 30 dB relative to the wanted signal. Usually this is of no consequence, but in cases where better carrier suppression is required, it is necessary to adjust the DC bias on the I and Q inputs to suppress the carrier.

While the architecture in Fig. 40 is generic in nature, practical implementation requires care in avoiding RF feedback. The use of up conversion architectures and modulation at a fixed transmitter IF can reduce modulation distortion and out-of-band emissions.

While the arrangement illustrated in Fig. 40 utilizes two bi-phase AM modulators, it is equally possible to use four uniphase modulators, and four orthogonal input channels.

A more complex, but more flexible, approach is to use a single path incorporating a digitally-controlled attenuator, and a digitally-controlled phase-shifter. These two components are driven by the baseband input by way of a look-up table (memory matrix), allowing the direct generation of virtually any (digital) modulation scheme.

2 Filtering

Filtering (generally bandpass filtering) of the transmitter output can be used in conjunction with the other techniques discussed in this Annex to reduce the residual spurious output levels. The choice of the type of filter to be used is, as usual, a compromise between a number of interacting, usually conflicting, requirements such as out-of-band rejection, passband attenuation, time domain response, size, weight, cost, etc.

Filter designs are usually based on the classical analytically derived categories such as Butterworth, Chebyshev, etc. Some of these categories are optimized for one of its characteristics at the expense of others, and some provide compromises between characteristics as summarized in Table 13.

TABLE 13

Comparison of the different categories of the filters

Category	Optimized parameter	Sacrificed parameter
Butterworth	Passband amplitude flatness	Out-of-band rejection
Chebyshev	Out-of-band rejection	Passband amplitude flatness and attenuation
Bessel	Passband delay flatness	Out-of-band rejection
Elliptic (Cauer-Chebyshev)	Close-in out-of- band rejection (theoretically infinite at spot frequencies)	Out-of-band rejection away from spot frequencies

Other categories provide compromises between characteristics. For example, the so-called linear phase filter can be designed to provide a passband flatness approaching that of the Bessel filter, but with improved out-of-band rejection. Similarly, transitional filters have a near linear phase shift and smooth amplitude roll-off in the passband, with improved out-of-band rejection compared to a Bessel filter (but still significantly less than a Chebyshev filter).

As well as the characteristics described above, another factor which defines the performance of any filter is its order of complexity, which is related to the number of poles and/or zeros in its transfer function. In general, increasing the order of complexity improves the performance of the optimized characteristic at the expense of degrading the performance of the sacrificed characteristic(s).

Fig. 41 shows examples of the out-of-band rejection (which is the main performance parameter of interest in the context of this study) for Butterworth, Chebyshev and Elliptic filters of order of $n = 3$. Note that the low-pass response is shown; in a practical design the bandpass response would be derived from this by suitable scaling of the frequency axis. Figure 41 therefore illustrates the relative performance of these filter types.

FIGURE 41
Comparison of Butterworth, Chebyshev and Elliptic filters, $n = 3$

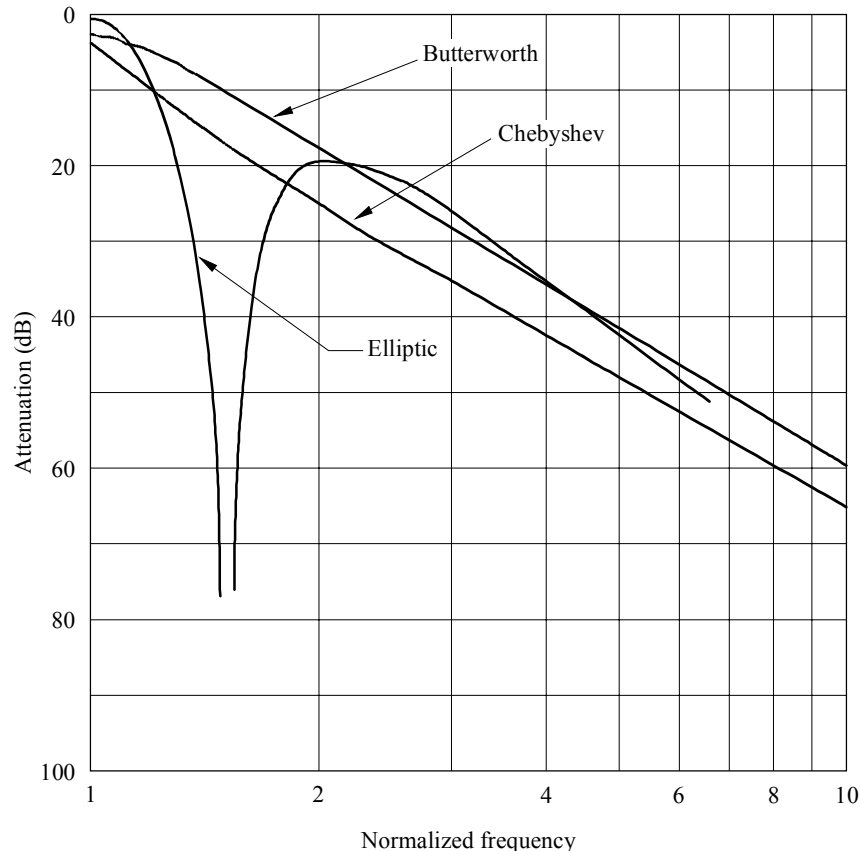

0328-41

Figure 42 shows examples of the out-of-band rejection for similar filters of order of $n = 7$. The improved performance of these filters compared with those in Fig. 41 can only be obtained by increased implementation complexity and, in practice, increased insertion loss in the wanted frequency band.

Transmitter output filtering nearly always requires the use of resonant elements such as tuned circuits or transmission lines to form filter structures. Although surface acoustic wave (SAW) filters have been produced for operation at up to 2 GHz, these have relatively low power handling. The insertion loss of SAW filters also tends to be quite high, up to 6 dB for SAW resonator filters, and up to 30 dB for transversal (delay line) filters.

At frequencies up to a few hundred MHz, inductor capacitor filters are usually used to achieve bandwidths of 10% or more. Narrower bandwidths are possible, but the unloaded Q tolerances and temperature stability of the components generally precludes significant further reduction.

At higher frequencies, up to a few GHz, the most used filter technologies are printed microstrip and silver plated ceramic. Microstrip filters are generally limited to bandwidths no less than a few per cent, due to tolerances of the dielectric constant, substrate thickness and etching variability. The unloaded Q of microstrip resonators (typically < 200) also limits the minimum practical bandwidth due to insertion loss considerations.

FIGURE 42
Comparison of Butterworth, Chebyshev and Elliptic filters, $n = 7$

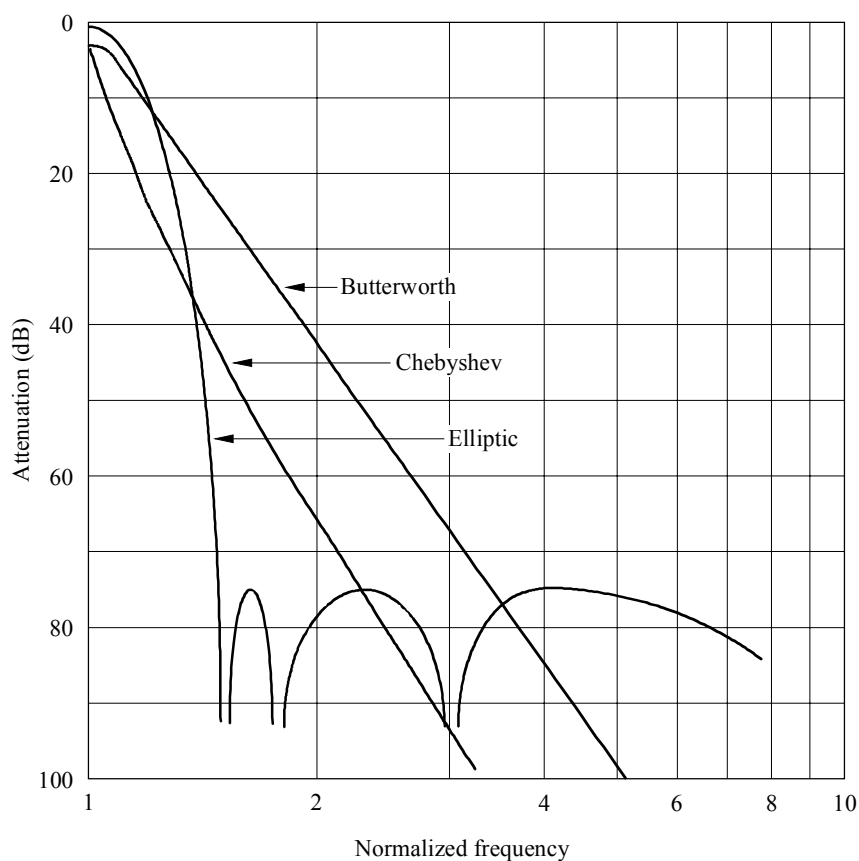

0328-42

The use of silver plated ceramic technology can achieve better performance owing to the higher unloaded Q and excellent stability of the materials used. The digital cellular and cordless telephone industry in particular, has prompted the development of very high dielectric constant, low loss ceramics for use in miniature coupled resonator filters. A typical 2-pole 1.9 GHz filter for example, can achieve an insertion loss of 0.8 dB with a bandwidth of 1%.

At frequencies of several GHz and above, the resonant elements tend to be cavities or transmission lines with an air dielectric. A common configuration is the interdigital filter, where several resonant fingers are positioned within a single cavity to give the desired coupling, and hence overall filter response. Performance is comparable with that of silver plated ceramic filters, with bandwidths available as low as 0.2%.

An example of the mitigation available, and the cost at which it is achieved is given by the filtering used at some UHF television transmitters to protect the radio astronomy service. As described above, interference is possible to radio astronomy receivers operating at 610 MHz from the adjacent channel, recently assigned to high-power analogue television transmitters. The transmitter operators have, therefore, installed high power filtering at certain transmitters to reduce the emission of further modulation sidebands and intermodulation products. In the case of a particular transmitter site, it has been necessary to install a 12-pole filter, allowing a rejection, 2 MHz below the band-edge, of some 80 dB. This degree of filtering, however, is only achieved at a cost amounting to some 25% of the entire transmitter installation.

3 Modulation techniques

In transmitters intended for single carrier applications, the choice of modulation scheme can significantly affect the level of adjacent channel energy. Paradoxically, schemes which can potentially give the most constrained spectrum, often result in the worst performance, in this respect.

Figure 43 shows the theoretical normalized power spectral densities of various modulation schemes. From this it can be seen that in the simplest case, BPSK, the adjacent channel energy reduces very slowly with offset from the carrier frequency.

FIGURE 43

Power spectral densities of some example modulation schemes

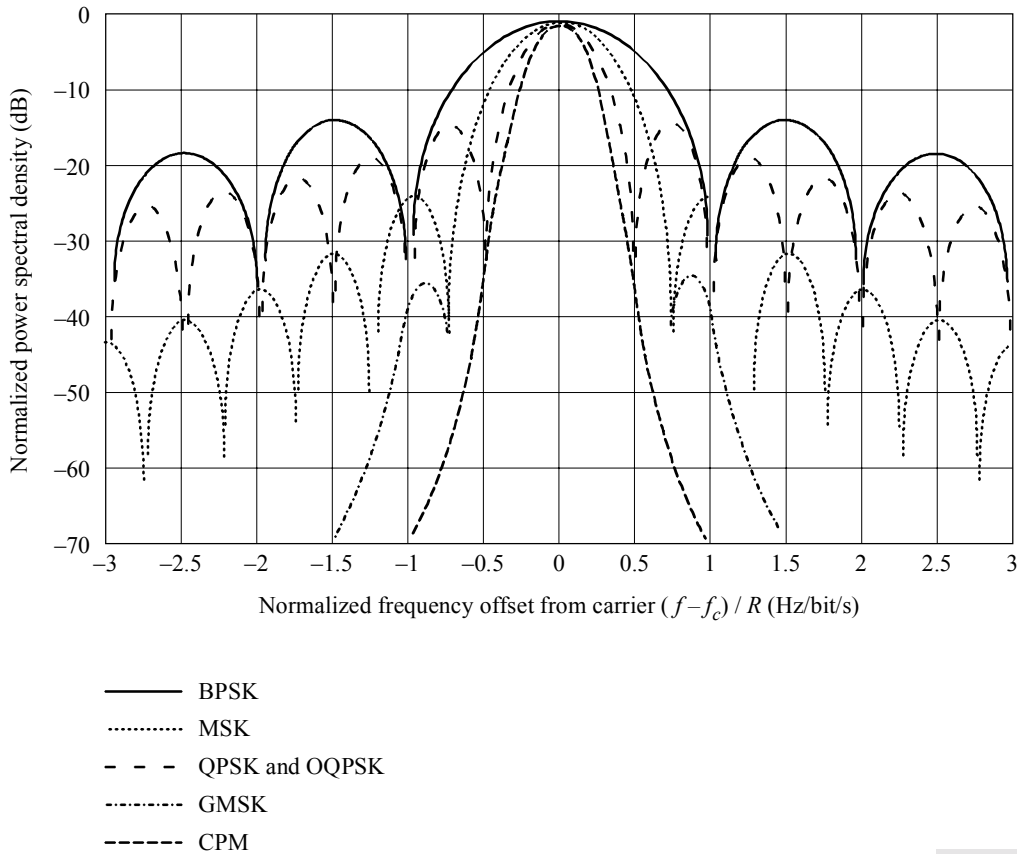

0328-43

Unfiltered QPSK and OQPSK have a narrower main lobe but otherwise show only a marginal improvement in suppression of adjacent channel energy. OQPSK can give much lower out-of-band energy by filtering the baseband signals before modulation. A root raised cosine filter for example, can theoretically give infinite adjacent channel rejection. However, in practice, the filtering has a limited stopband and, more importantly, since OQPSK is a non-constant envelope scheme, power amplifier non-linearity causes spectral regrowth through AM to AM and AM to PM conversion.

MSK without baseband filtering has an improved rate of reduction of out-of-band energy. This can be further improved by the addition of Gaussian baseband filtering, (GMSK). The degree of improvement depends on the parameters of the filter used, the example shown in Fig. 43 is for the case where the time-bandwidth product is 0.3 (as used in a cellular radio system). It can be seen that this scheme gives only moderate adjacent channel performance (typically -40 dBc at offsets comparable with the symbol rate), but since it is a constant envelope technique it has the advantage that a limiting power amplifier can be used.

GMSK can be regarded as a special case of a class of constant envelope modulation techniques known as CPM. As in the case of GMSK the details of the power spectral density of the CPM signal depends on various parameters. The example shown is the case of a 4-level signal, modulation index 0.33 and raised cosine baseband filtering of 3-symbol duration.

In practice, limitations in the accuracy with which these advanced modulation schemes can be implemented restrict the degree of suppression of out-of-band energy that can be achieved. The signal envelope is nearly but not exactly constant, so the power amplifier non-linearity can still cause some spectral regrowth, although this effect is not as severe as in the case of OQPSK.

A recent development is the use of coded orthogonal frequency division multiplexing (COFDM) in digital broadcasting (audio and video), see Annex 6, § 5. This modulation technique produces a comb of carriers, usually separated by a few kHz, where each carrier is modulated at a low symbol rate by orthogonal data streams. The overall spectrum is therefore almost rectangular. However, the amplitude distribution of such a signal is virtually noise-like, back-off is required in the power amplifier to allow for the peak to mean ratio. Clearly, amplifier non-linearity is also a problem with this technique.

In multi-carrier systems, where a single power amplifier is used to amplify several carriers, the problem is compounded by intermodulation products between carriers. In this case, unwanted products can be generated at multiples of the carrier spacing. The application of suitable coding techniques can reduce the peak-to-average power ratio of the signal by factors as high as 15 dB: these techniques ensure that the particular orthogonal data codes which could add in phase to give high peak powers are suppressed.

4 Linearization

RF amplifier linearization techniques can be broadly divided into two main categories:

- open-loop techniques, which have the advantage of being unconditionally stable, but have the drawback of being unable to compensate for changes in the amplifier characteristics;
- closed-loop techniques, which are inherently self-adapting to changes in the amplifier, but can suffer from stability problems.

The following sections review linearization techniques.

4.1 Predistortion

Rather than using a method that responds to the actual instantaneous characteristics of the HPA, it is common to pre-distort the input signal to the amplifier, based on *a priori* knowledge of the transfer function. Such pre-distortion may be implemented at RF, IF or at baseband. Baseband linearizers, often based on the use of look-up tables held in firmware memory are becoming more common with the ready availability of very large scale integration techniques, and can offer a compact solution. Until recently, however, it has been easier to generate the appropriate pre-distortion function with RF or IF circuitry.

This involves placing a compensating non-linearity into the signal path, ahead of the amplifier to be linearized, as shown in Fig. 44. The signal is thus pre-distorted before being applied to the amplifier. If the pre-distorter has a non-linearity which is the exact inverse of the amplifier non-linearity, then the distortion introduced by the amplifier will exactly cancel the pre-distortion, leaving a distortionless output.

FIGURE 44

Pre-distortion concept

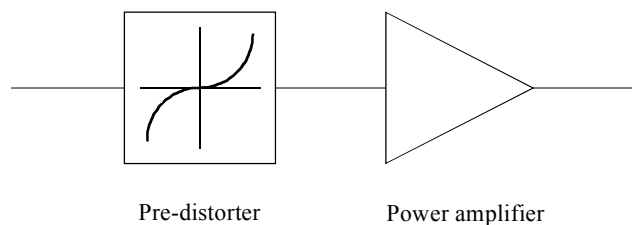

0328-44

In its simplest analogue implementation, a practical pre-distorter can be a network of resistors and non-linear elements such as diodes or transistors. Several examples of this technique have appeared in the literature, where the reduction in third order intermodulation distortion that has been reported is typically in the range 7-15 dB. The poor performance is due to the fact that the amplifier characteristics are not constant, but vary with time, frequency, power level, supply voltage and environmental conditions.

Better results have been reported, where a pair of field effect transistor amplifiers are used as the pre-distorter, as shown in Fig. 45. In this arrangement, the input signal is unequally split between the two amplifiers, such that one of them is driven into compression. The compressed output is then scaled and subtracted from the linear output to produce the inverse of the compression characteristic, as required. Reduction in intermodulation distortion of around 20 dB has been measured using this technique, but only when the main amplifier is operated with at least 1 dB of back-off.

FIGURE 45
Soft-limiter pre-distortion

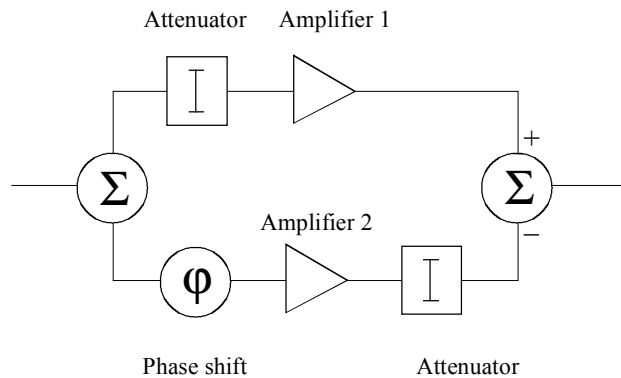

0328-45

Although adaptive predistortion schemes have been reported, where the non-linearity is implemented in digital signal processing, they tend to be very computationally or memory intensive, and power hungry.

4.2 Feedforward

The feed-forward linearization technique compares the amplified signal with an appropriately delayed version of the input signal and derives a difference signal, representing the amplifier distortions. This difference signal is in turn amplified, and subtracted from the final HPA output. The main drawback of the method is the requirement for a second amplifier, which may be of lower power rating. The technique can, however, deliver an increase in output power rating of some 3 dB when used with a travelling wave tube.

Feedforward involves comparing the power amplifier input and output signals to derive an error or distortion term in a signal cancelling loop. This residual error is then amplified in a separate, low power amplifier before being subtracted from the main amplifier output in an error cancelling loop. This is shown in Fig. 46. If the low power, auxiliary amplifier is perfectly linear and the error cancelling loop is perfectly balanced, then the overall result is distortionless amplification. However, in practice the cancellation loops are only partially effective, and the technique is compromised, although it is widely used.

In a practical feedforward implementation, there will be imbalance in the error cancelling loop which will limit the distortion reduction. For example, a 1 dB gain error and a 10° phase error limits the distortion suppression to just 14 dB. To improve this to say, 30 dB, would require the balancing to be within 0.3 dB and 1° . Even if such stringent requirements can be met, the overall linearity can never be better than that of the auxiliary amplifier, which must therefore operate in Class-A and will consequently be inefficient. These problems are further compounded by errors in the signal cancelling loop, which will increase the power handling requirements of the auxiliary amplifier. A gain error of 2 dB and a phase error of 10° , for example, demands that the second amplifier output power is only 12 dB below that of the main amplifier.

FIGURE 46
Feedforward

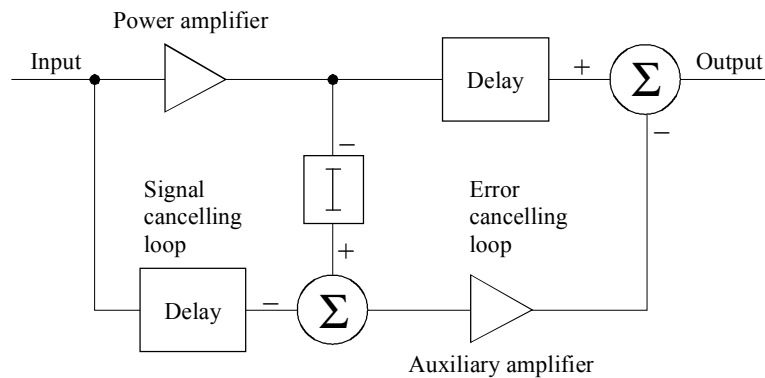

0328-46

An example of a practical application of feedforward concerned a 30 W HF amplifier. Here, the auxiliary amplifier had the same power rating as the main amplifier, yet the distortion reduction achieved was still no more than 15 dB across the band. Interestingly, when the two amplifiers were connected in parallel with each one operating at half power, the results were little worse.

The technique is widely used in cellular base stations and typically provides distortion cancellations of greater than 30 dB in a 20 MHz bandwidth.

4.3 Feedback

In audio amplifiers, linearization may readily be achieved by the use of feedback, but this is less straightforward at high RF frequencies due to limitations in the available open-loop amplifier gain. It is possible, however, to feedback a demodulated form of the output, to generate adaptive pre-distortion in the modulator. It is clearly not possible to apply such an approach in a bent-pipe transponder (frequency translation only and no on-board demodulation), however, where the modulator and HPA are rather widely separated.

Negative feedback is the most well-known linearization technique and is widely used in low frequency amplifiers, where stability of the feedback loop is easy to maintain. With multi-stage RF amplifiers however, it is usually only possible to apply a few dB of overall feedback before stability problems become very difficult. This is mainly due to the fact that, whereas at low frequency it can be ensured that the open-loop amplifier has a dominant pole in its frequency response (guaranteeing stability), this is not feasible with RF amplifiers because their individual stages generally have similar bandwidths.

Of course, local feedback applied to a single RF stage is often used, but since the distortion reduction is equal to the gain reduction, the improvement obtained is necessarily small because there is rarely a large excess of open loop gain available.

4.4 Modulation feedback

At a given centre frequency, a signal may be completely defined by its amplitude and phase modulation. Modulation feedback exploits this fact by applying negative feedback to the modulation of the signal, rather than to the signal itself. Since the modulation can be represented by baseband signals, we can successfully apply very large amounts of feedback to these signals without the stability problems that beset direct RF feedback.

Early applications of modulation feedback used amplitude (or envelope) feedback only, applied to valve amplifiers, where amplitude distortion is the dominant form of non-linearity. With solid-state amplifiers however, phase distortion is highly significant and must be corrected in addition to the amplitude errors. The first successful practical implementation of simultaneous amplitude and phase feedback is known as the Polar Loop technique.

4.5 The Polar Loop technique

The Polar Loop technique is based around the principle of envelope elimination and restoration, but modified to allow feedback to be applied. A block diagram of the Polar Loop technique is shown in Fig. 47.

FIGURE 47
The Polar Loop technique

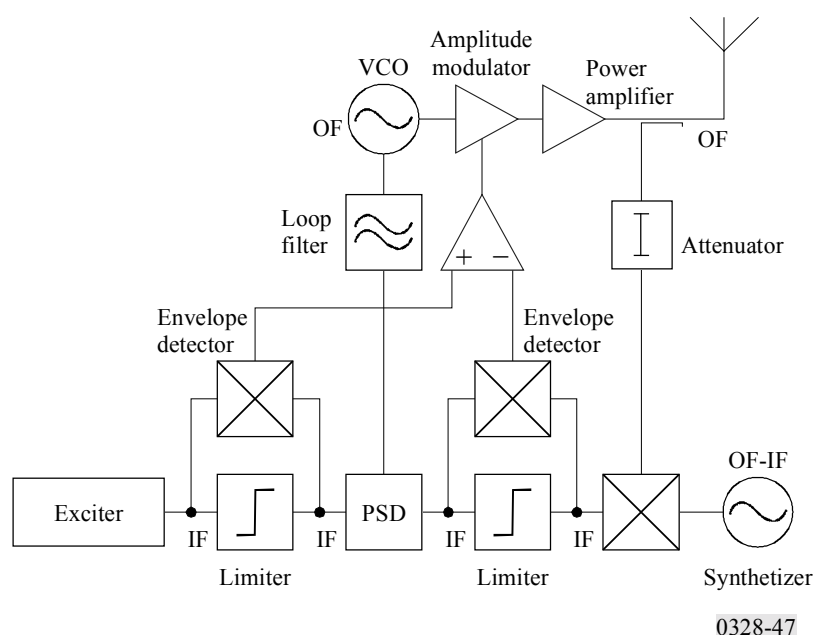

The RF stages of the system are particularly simple. They consist of a voltage controlled oscillator running at the output frequency (OF), which generates the phase component of the output signal, an amplitude modulated stage which generates the amplitude component, and the main power amplifier.

The input signal to the Polar Loop is first generated at IF and at low power level (shown as the exciter block in the diagram). It is then resolved into polar coordinate form by envelope detection to produce the amplitude component, and hard-limiting to give the phase component. The envelope detection is conveniently achieved by multiplying the input signal by the limiter output in a double balanced mixer (a process equivalent to full-wave rectification). A sample of the final RF output is translated (usually down) to the same frequency as the input signal, and is similarly resolved into its polar coordinates. The two envelope signals are then compared in a high gain differential amplifier which in turn controls the amplitude modulator, forming an envelope feedback system. The two phase modulated signals are phase compared in a phase sensitive detector (PSD), and the amplified error signal controls the VCO forming a phase locked loop. The overall effect is that two orthogonal feedback loops are formed, which by suitable choice of loop gain and bandwidth, attempt to make the amplitude and phase of the output signal closely approach that of the IF input.

The two main limiting factors in the performance of a Polar Loop system are:

- the balance between the two polar resolving circuits (limiters + mixers);
- the relative bandwidths of the feedback loops and the amplitude and phase spectra (which determines the amount of negative feedback available).

In practical Polar Loop transmitters designed for narrow-band (5 kHz) applications, it has been found that the balance of the resolving circuits is the main problem, and this sets a minimum value to the residual third order intermodulation distortion of around -60 dBc. For wider bandwidth signals, it is the finite amount of feedback which is the main restriction. This is particularly true for signals where the envelope can fall to zero, as the zero-crossing often results in a sharp discontinuity in both the envelope and phase waveforms, and consequently produces envelope and phase spectra which are considerably wider than the composite signal bandwidth.

An alternative approach to modulation feedback, which overcomes both of the above problems is known as the Cartesian Loop technique and this is covered in the next section.

4.6 The Cartesian Loop technique

The Cartesian Loop technique makes use of the fact that a modulated RF signal can be represented in complex (I and Q) baseband form as well as by amplitude and phase functions.

If negative feedback is applied to I and Q rather than A and ϕ , this leads to the configuration shown in Fig. 48. The principal of operation is as follows.

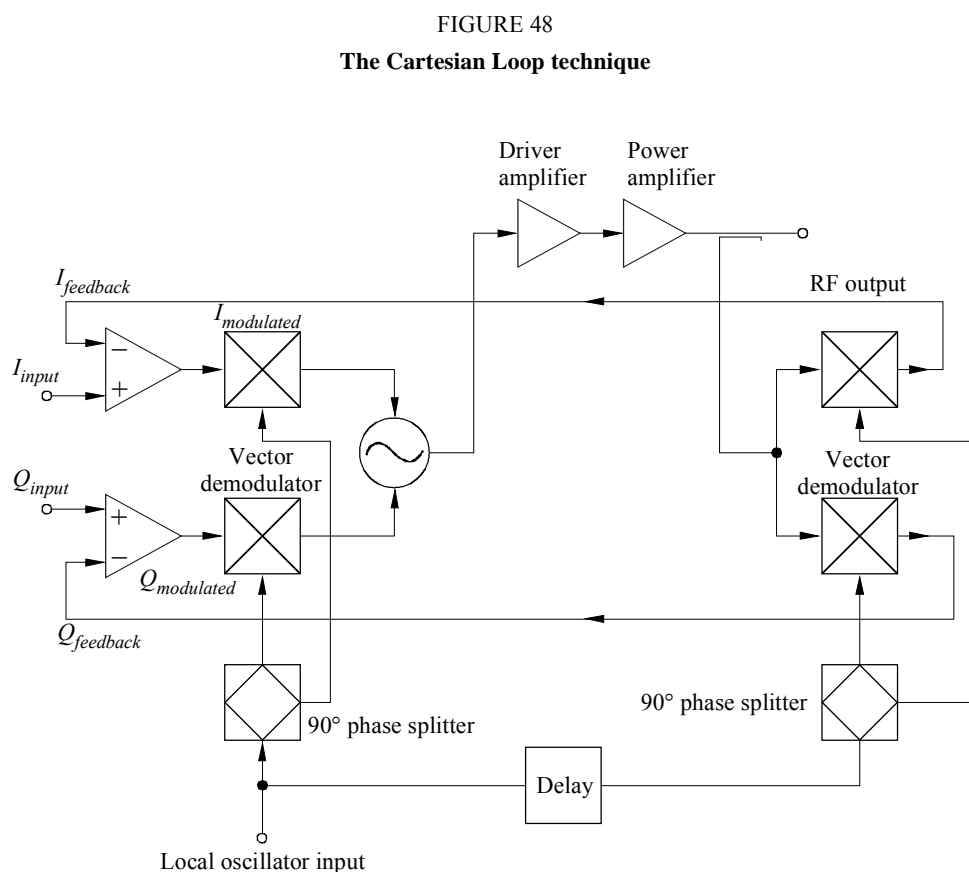

0328-48

Complex baseband signals, $I_{modulated}$ and $Q_{modulated}$, are used to modulate in-phase and quadrature local oscillator signals in double balanced mixers, and the combined output forms the input to the driver and power amplifier. A sample of the power amplifier output is fed to a second pair of mixers configured as demodulators which use the same local oscillators. The RF output is thus coherently demodulated back down to I and Q baseband. These signals, $I_{feedback}$ and $Q_{feedback}$, are then fed back and compared with the input signals, I_{input} and Q_{input} , in high gain differential amplifiers, the outputs of which form the inputs to the modulators, $I_{modulated}$ and $Q_{modulated}$. Just as in the Polar Loop, two orthogonal

feedback loops are thus formed which attempt to make the I and Q demodulated outputs closely approach the I and Q inputs. Note that because of the coherent nature of the feedback, the technique is identically equivalent to RF feedback, but because dominant loop poles are introduced by the differential amplifiers, a good phase margin of stability may be easily maintained, even when very large amounts of feedback are applied.

The delay element shown in Fig. 48 is to ensure that the RF output and the demodulating carriers are at the correct relative phase. Perfect alignment is not necessary owing to the compensating action of the loops.

The effectiveness of the Cartesian Loop depends on two factors:

- the ratio of the feedback loop bandwidths to the I and Q input bandwidths (determines the amount of feedback);
- linearity of the demodulators (since the I and Q demodulated outputs must be a linear representation of the RF output).

Note that unlike the Polar Loop, the RF output bandwidth is simply twice the I and Q bandwidth. We do not have the problem of generating wideband A and ϕ signals.

Practical Cartesian Loop transmitters have been constructed which operate with relatively narrow-band signals and these have achieved excellent results. On a two-tone test, third order intermodulation products are typically reduced by 40 dB, compared to the same transmitter with the power amplifier run open loop.

4.7 Summary

With the increasing use of baseband processing and remodulation in systems, the use of modulation feedback to improve HPA linearization has become possible. There are still considerable bandwidth limitations associated with these techniques. RF pre-distortion techniques are used especially where wide bandwidth amplifiers are required.
